

data sheet

76F-HCA series

stainless steel full port ball valve with 3/4" hose connection and protective cap



description

The "Apollo"® 76F-HCA series models are ideally suited for direct connection to hoses. Valves feature a heavy duty machined hose thread cap. Standard lever and nut are stainless steel.

size range

- 1/2" - 1"

connections

- NPT
- BSPP
- BSPT

configurations

- 76F-HCA series - hose cap

approvals

- MSS SP-110 ball valves
- Buy American Act (BAA)
- Build America Buy America (BABA) Act
- American Iron and Steel Act (AIS)



this specification is provided for reference only. we reserve the right to change any portion of this specification without notice and without incurring obligation to make such changes to Aalberts integrated piping systems products previously or subsequently sold.

Aalberts integrated piping systems

10715 Sikes Place / suite 200 / Charlotte / NC / 28277

aalberts-ips.us

features

- investment cast components
- reinforced seats
- blowout-proof stem design
- adjustable packing gland
- stainless steel lever and nut
- fire safe to API 607 (requires -24 suffix)
- meets NACE MR0175 (2000) & MR0103 (2012)
- CSA CGA 3.16-M88 (requires "GS" suffix)
- NSF/ANSI/CAN 61 Section 8, Annex G (1/4" to 2")
- NSF/ANSI 372 - drinking water system components - lead content
- hose cap rated to maximum pressure of 600 psig
- 100% factory tested
- manufactured in the USA - AIS, BABA and BAA compliant (requires -UA suffix)

component	material
body	A351-CF8M stainless steel
retainer	A276-316 stainless steel
cap	A276-316 stainless steel
ball	A276-316 stainless steel
seat (2)	RPTFE
stem	A276-316 stainless steel
gland	A276-316 stainless steel
stem packing	MPTFE
stem bearing	RPTFE
lever and grip	304 stainless steel with vinyl
body seal	RPTFE
lever nut	304 stainless steel

performance rating

CWP	SWP	temperature	vacuum service
1000 psig	125 psig (maximum)	500°F (maximum temperature)	29 in. Hg

job name	
job location	
engineer	
contractor	
tag	
PO#	
rep	
wholesaler dist	

data sheet

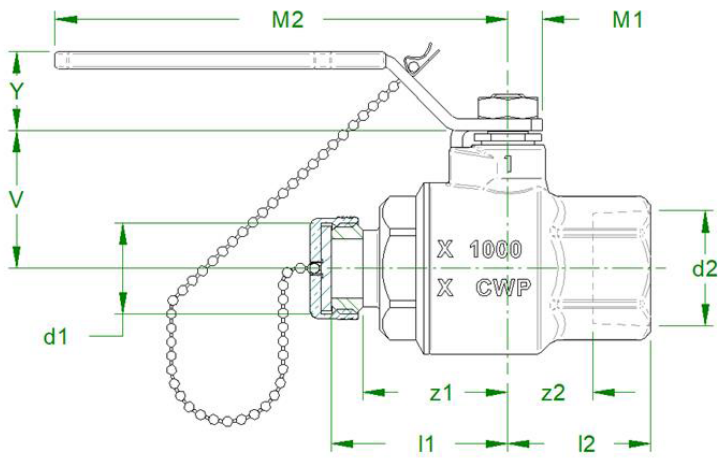

dimensions

NPT

part number	size	bore size	d1	d2	l1	l2	z1	z2	M1	M2	V	Y	weight	Cv
76F-103-HCA	½"	0.50"	1.06"	0.84"	1.41"	1.14"	1.05"	0.56"	0.37"	4.17"	1.09"	0.86"	0.63 lbs	15
76F-104-HCA	¾"	0.75"	1.06"	1.05"	1.81"	1.39"	1.45"	0.71"	0.38"	4.17"	1.31"	0.86"	1.00 lbs	51
76F-105-HCA	1"	1.00"	1.06"	1.32"	2.06"	1.67"	1.70"	0.88"	0.40"	5.29"	1.61"	0.92"	1.38 lbs	68