



BFMMPVB MAINTENANCE MANUAL



SERIES 4V-500

$\frac{1}{2}$ " - 2"

Pressure Type Vacuum Breaker

Conbraco Industries, Inc., P.O. Box 247
Matthews, North Carolina 28106
Phone 704 841-6000
Fax 704 841-6020
www.conbraco.com

DESCRIPTION

The Conbraco Model 4V-500 Series Pressure Type Vacuum Breaker consists of a replaceable check valve cartridge and a unique one-piece atmospheric vent-cap/float assembly located between two resilient seated shut-off valves. The modular design allows for unprecedented ease of inspection and maintenance.

OPERATION

During normal flow conditions, the check valve remains open and the float seals on the cap assembly. As the line pressure falls to 1 psig, a spring-loaded atmospheric vent valve opens, breaking the vacuum and thereby preventing back-siphonage. In the event of exposure to freezing temperatures, a spring-loaded relief valve in the float protects the PVB body and internal components from damage. As the temperature increases above freezing, the relief valve automatically reseats. During normal operating conditions, the relief valve will not discharge.

INSTALLATION INSTRUCTIONS

Pressure vacuum breaker assemblies should be installed at least 12 inches above the highest piping or outlet downstream of the device and with the supply line connected to the bottom of the device as shown in Figure 1. Install the device in an accessible location to facilitate periodic field-testing and any required maintenance. Contact local water authorities for installation/service requirements.

OTHER INSTALLATION TIPS

Flush upstream piping thoroughly to remove foreign matter prior to installation. Use pipe dope sparingly on external threads only. When initially pressurizing the device some spillage of water from the air inlet may occur.

FIELD TESTING PROCEDURE

It is important that the device be tested periodically in compliance with local codes, but at least once a year or more as service conditions warrant. For problems encountered during testing, refer to troubleshooting and maintenance sections.

EQUIPMENT REQUIRED

Differential Pressure Test Kits: Conbraco Model 40-200-TK (Aluminum Housing), 40-200-TK5 or 40-200-TKP (Acetal Housing).

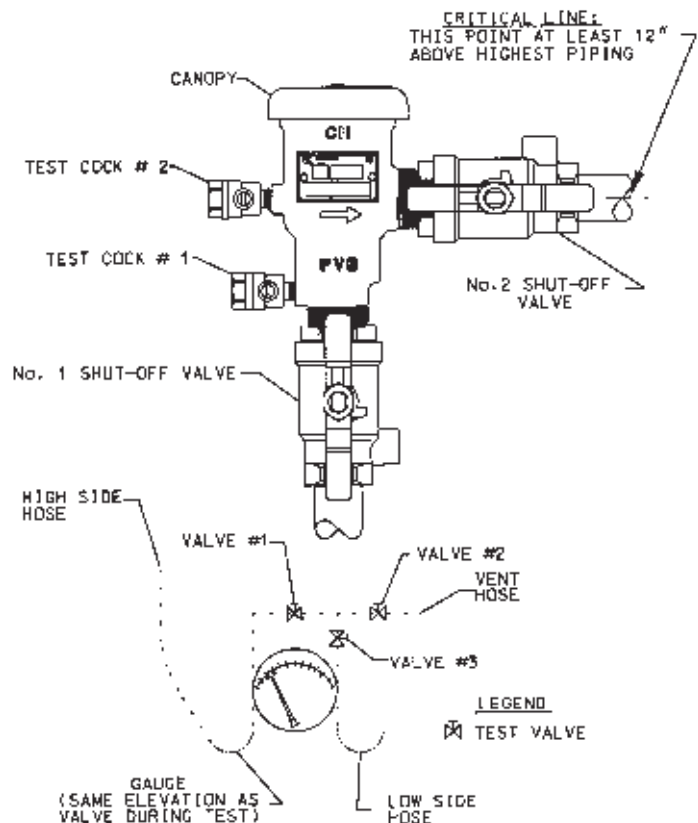

FIGURE 1

TEST NO. 1

Air Inlet Operation Test

REQUIREMENT

The air inlet shall open before internal pressure falls below 1 psig.

PROCEDURE

NOTE: During all testing the gauge and vent hose end must be at the elevation of the device being tested (see Figure 1).

1. Remove the air inlet canopy.
2. Open test valve #2 and close test valves #1 and #3.
3. Install the high side hose to test cock #2 (low side hose open to atmosphere during test) and bleed all air by opening test valve #1.
4. Close #2 shut-off valve, then close #1 shut-off valve.
5. Slowly open test valve #1. Note the pressure differential at which the air inlet opens.

TEST NO. 2

Drip Tightness of Check Valve

REQUIREMENT

The check valve shall be drip tight when the inlet pressure is at least 1 psig and the outlet pressure is atmospheric.

PROCEDURE

1. Install the high side hose to test cock #1. Open test cock #1 and bleed air by opening test valve #1. Close test valve #1.
2. Close #1 shut-off valve. Open test cock #2. The air inlet will open and water will drain from the body until the check has sealed.
3. Record the pressure shown on the gauge.
4. Close all test cocks, remove test equipment and repressurize the valve.

MAINTENANCE

(1/2" – 1 1/2" models)

A. DISASSEMBLY

1. Close #2 shut-off valve, then close #1 shut-off valve.

TROUBLESHOOTING GUIDE

SYMPTOM	CAUSE	CORRECTIVE ACTION
1. Air inlet fails to open.	A. Float assembly improperly assembled to cap assembly. B. Float o-ring sticking to cap.	A. Rotate float to eliminate binding on cap. B. Clean float seat area on cap and replace float o-ring.
2. Air inlet fails to close.	A. Float assembly improperly assembled to cap assembly. B. Float o-ring fouled with debris.	A. Rotate float to eliminate binding on cap. B. Clean float seat area on cap and remove debris.
3. Check valve fails to hold 1 psig.	A. Check valve fouled with debris. B. Check valve seat damaged.	A. Remove, clean or replace check valve. B. Replace check valve (1/2"-1 1/2" models or replace seat (2" model).
4. Water continues to flow from test cock #2 during Test No. 2.	A. #1 shut-off valve not completely closed.	A. Close #1 shut-off valve.

2. Bleed pressure from device by opening test cocks #1 and #2.
3. Remove the air inlet canopy.
4. Unscrew and remove the cap and float assembly. DO NOT USE CANOPY TO UNSCREW CAP! DAMAGE TO THE CAP MAY OCCUR. Inspect float and freeze plug seats for damage or fouling debris.
5. If fouling of check valve is suspected, unscrew check from valve body (or from check retainer on 1¼" and 1½" models), remove fouling debris, and reinstall.

B. ASSEMBLY

1. Apply a thin coat of silicone-based lubricant to the check valve o-ring. Press check valve assembly into body (or into check retainer on 1¼" and 1½" models) until it snaps into place.
2. Apply a thin coat of silicone-based lubricant to the cap o-ring. Screw cap and float assembly onto PVB body.
3. Test device to insure proper operation.
4. Install air inlet canopy.

MAINTENANCE (2" model)

A. DISASSEMBLY

1. Close #2 shut-off valve, then close #1 shut-off valve.
2. Bleed pressure from device by opening test cocks #1 and #2.

3. Remove the air inlet canopy.
4. Unscrew and remove the cap and float assembly. DO NOT USE CANOPY TO UNSCREW CAP!

DAMAGE TO THE CAP MAY OCCUR. Inspect float and freeze plug seats for damage or fouling debris.

5. If fouling of check valve is suspected, unscrew disc-retaining guide from valve body, remove spring, and check valve assembly. Inspect seat disc for damage or fouling debris. Seat disc may be turned over for a temporary repair, but should be replaced if damaged. If check valve is not repairable, replace with repair kit. See parts list for repair kit part numbers.

B. ASSEMBLY

1. Install check valve into replaceable seat.
2. Replace spring and screw disc retaining guide into body (stem must point downward toward check valve).
3. Apply a thin coat of silicone-based lubricant to the cap o-ring. Screw cap and float assembly onto PVB body.
4. Test device to insure proper operation.
5. Install air inlet canopy.

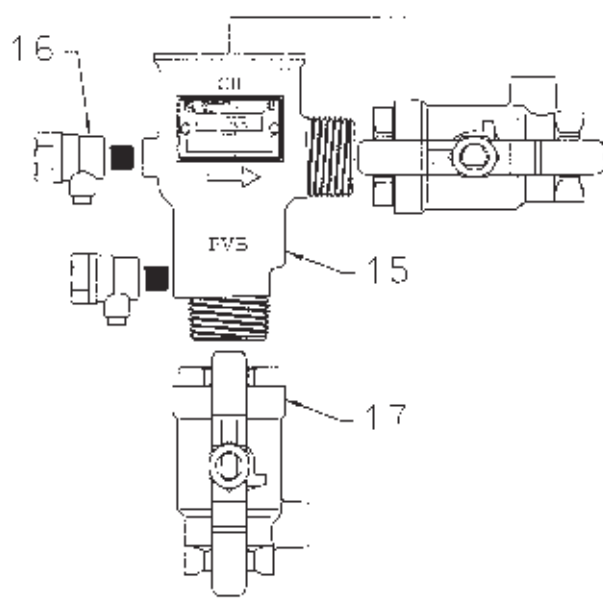

1/2" - 1 1/2" PVB

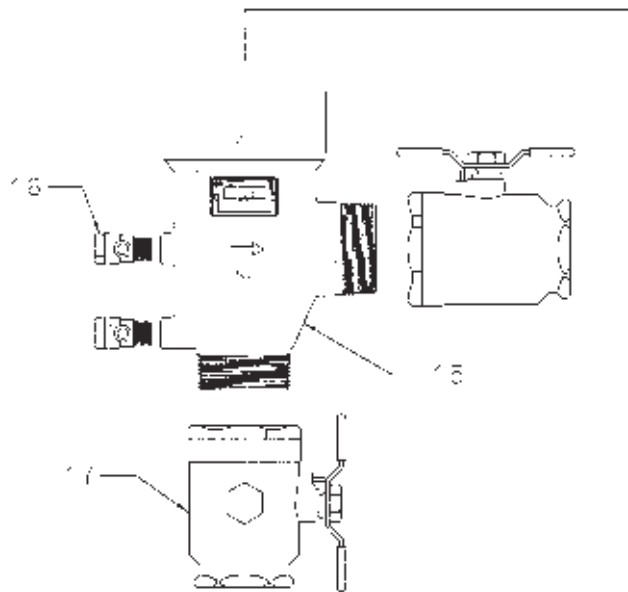
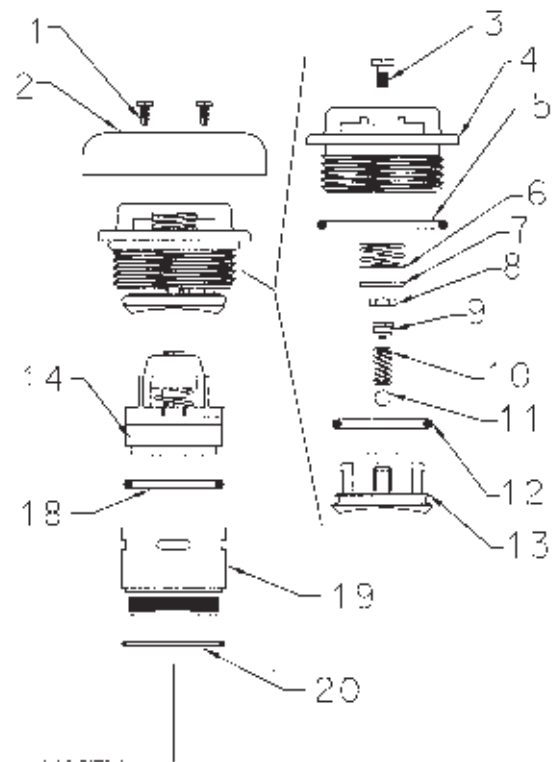

2" PVB

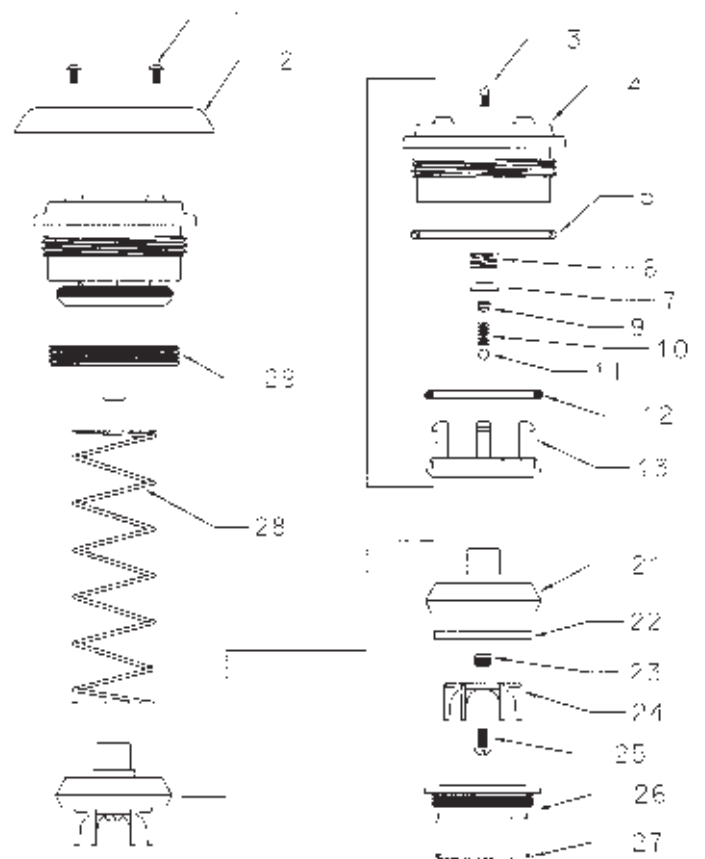

CONBRACO PVB SERIES PARTS LIST

ITEM NO.	DESCRIPTION	QTY	1/2" PVB 4V-503-02	3/4" PVB 4V-504-02	PART NUMBERS			
					1" PVB 4V-505-02	1-1/4" PVB 4V-506-02	1-1/2" PVB 4V-507-02	2" PVB 4V-508-02
1	Canopy Screw	2	B-2309-00	B-2309-00	B-2309-00	B-1864-00	B-1864-00	B-1864-00
2	Canopy	1	F-3129-08	F-3129-08	F-3129-08	E-2234-08	E-2234-08	E-2787-00
3	Cap Screw	1	B-2308-00	B-2308-00	B-2308-00	B-2308-00	B-2308-00	B-2308-00
4	Cap	1	F-3133-00	F-3133-00	F-3133-00	F-3197-00	F-3197-00	F-3237-00
5	Cap O-Ring	1	D-3650-00	D-3650-00	D-3650-00	D-3821-00	D-3821-00	D-3906-00
6	Cap Spring	1	A-2147-00	A-2147-00	A-2147-00	A-1969-00	A-1969-00	A-1969-00
7	Cap Washer	1	E-2417-00	E-2417-00	E-2417-00	E-2417-00	E-2417-00	E-2479-00
8	Cap Nut	1	C-1991-00	C-1991-00	C-1991-00	C-1991-00	C-1991-00	N/A
9	Freeze Plug	1	K-3825-06	K-3825-06	K-3825-06	K-3825-06	K-3825-06	K-3825-06
10	Freeze Spring	1	A-1968-00	A-1968-00	A-1968-00	A-1968-00	A-1968-00	A-1968-00
11	Freeze Ball	1	I-6183-00	I-6183-00	I-6183-00	I-6183-00	I-6183-00	I-6183-00
12	Float O-Ring	1	D-3649-00	D-3649-00	D-3649-00	D-3650-00	D-3650-00	D-2040-00
13	Float	1	K-3815-00	K-3815-00	K-3815-00	K-3900-00	K-3900-00	K-3957-00
14	Check Valve	1	F-3135-00	F-3135-00	F-3134-00	F-3230-00	F-3230-00	N/A
15	PVB Body	1	Q-5541-05	Q-5542-05	Q-5540-05	Q-5607-05	Q-5608-05	Q-5646-05
16	Test Cock	2	78-257-01	78-257-01	78-257-01	78-258-01	78-258-01	78-258-01
17	Ball Valve	2	7B-103-31	7B-104-31	7B-105-31	7B-106-31	7B-107-31	7B-108-31
18	Check Valve O-Ring	1	N/A	N/A	N/A	D-3895-00	D-3895-00	N/A
19	Check Valve Retainer	1	N/A	N/A	N/A	F-3747-00	F-3747-00	N/A
20	Retainer O-Ring	1	N/A	N/A	N/A	D-2039-00	D-2039-00	N/A
21	Disc Retainer	1	N/A	N/A	N/A	N/A	N/A	K-4348-00
22	Seat Disc	1	N/A	N/A	N/A	N/A	N/A	D-4454-00
23	Plug	1	N/A	N/A	N/A	N/A	N/A	K-4349-06
24	Check Valve Guide	1	N/A	N/A	N/A	N/A	N/A	E-2242-00
25	Check Valve Screw	1	N/A	N/A	N/A	N/A	N/A	B-1878-00
26	Replaceable Seat	1	N/A	N/A	N/A	N/A	N/A	F-3748-00
27	Seat O-Ring	1	N/A	N/A	N/A	N/A	N/A	D-2556-00
28	Check Valve Spring	1	N/A	N/A	N/A	N/A	N/A	A-1701-00
29	Disc Retainer Guide	1	N/A	N/A	N/A	N/A	N/A	L-6162-00
	Check Valve Repair Kit (1/2"-1": Items 5 & 14) (1 1/4"-1 1/2": Items 5,14,18-20)	1	4V-500-01	4V-500-01	4V-500-02	4V-500-06	4V-500-06	N/A
	Check Valve & Seat Repair Kit (Items 21-27)	1	N/A	N/A	N/A	N/A	N/A	4V-500-07
	Cap & Float Ass'y Repair Kit (Items 3-13)	1	4V-500-03	4V-500-03	4V-500-03	4V-500-05	4V-500-05	4V-500-09

N/A = Not Applicable