

"Apollo"®



INSTALLATION, OPERATION & MAINTENANCE MANUAL

40-300 Series (1/2") | 4S-100 Series (1/2") | 40-100 Series (3/4" - 2")

40-100-T Series (3/4" - 2") | 40-100 Series (2-1/2" - 10") | 40-600 Series (3" - 10")

ES1594 IOM BFMM4001 rev.b

INSTALLATION, OPERATION & MAINTENANCE MANUAL

SECTION	DESCRIPTION	PAGE
I	Description and Operation	3
II	Installation	3
III	Troubleshooting Guide	5
IV	Maintenance Instructions 1/2" (40-103)	5
V	Maintenance Instructions 1/2" (4S-103)	6
VI	Maintenance Instructions 3/4" - 2"	7
VII	Maintenance Instructions 2-1/2" - 10"	7
VIII	Testing Procedures 1/2" - 10"	8-11
Parts List		
	40-300, 1/2"	12
	4S-103, 1/2"	13
	40-100, 3/4" - 2"	14-17
	2-1/2" - 10"	18-21
	3" - 10" DCDA	22-25

I. DESCRIPTION AND OPERATION

The Double Check Valve (DCV) device consists of two independently acting, spring loaded check valves. Two resilient seated shut-off valves and four test cocks complete the assembly.

Each check is designed to maintain a minimum of 1 psi across the valve during normal operation. If at any time the pressure downstream of the device increases above the supply pressure, both check valves will close to prevent any backflow from occurring.

The various styles and sizes of Double Check Valves are illustrated in figures 1, 2, 3, 4 and 5.

II. INSTALLATION

1. The DCV must be installed in an accessible location to facilitate periodic field testing and maintenance.
2. Flush all upstream piping thoroughly to remove foreign matter prior to installing the device.
3. The device should be installed horizontally for ease of maintenance and testing. A clearance between the lower most portion of the device and flood grade or floor should be provided for ease of maintenance.
4. When shut-off valves are provided separately, they should be installed with a test cock on the upstream side of the inlet shut-off valve.
5. After installing the assembly and with downstream or #2 shut-off valve closed, pressurize the device and bleed air through test cock #4. Then open #2 shut-off valve.

FIGURE 1
1/2" - 40-103

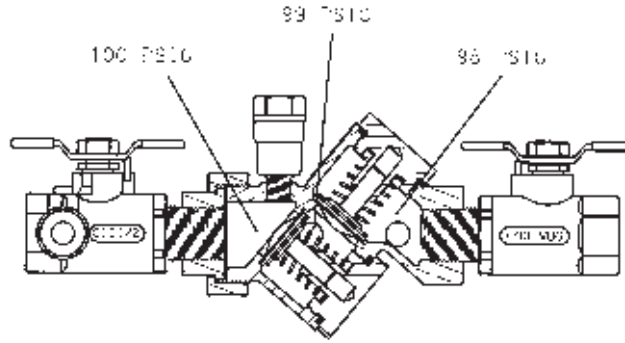

FIGURE 2
40 - 10X-A2
Y - PATTERN
NO FLOW CONDITION

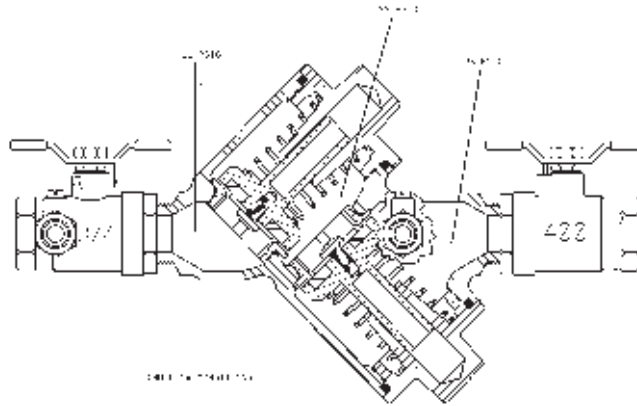

FIGURE 2
1/2" - 4S-103
NO FLOW CONDITION

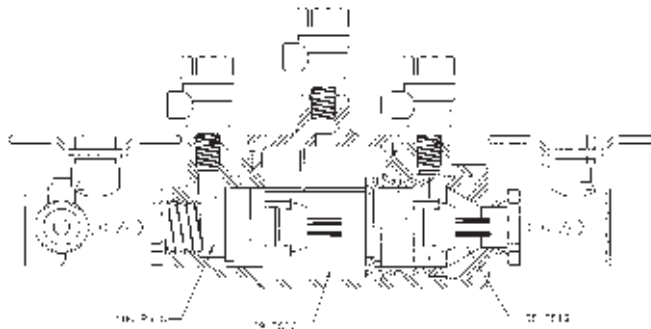

FIGURE 4
40 - 10X - T2
TOP ENTRY
NO FLOW CONDITION

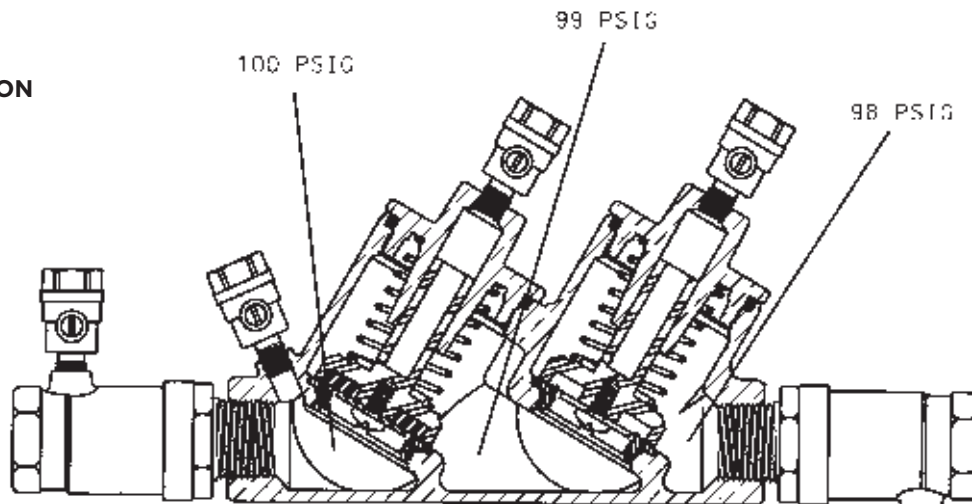
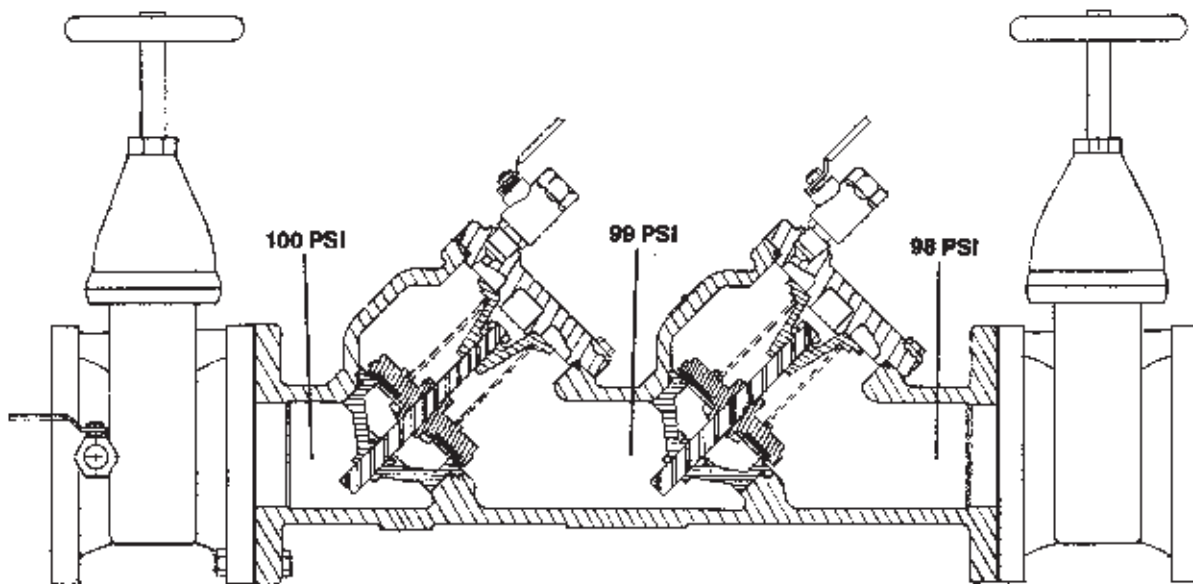

FIGURE 5
NO FLOW CONDITION



DOUBLE CHECK DETECTOR ASSEMBLY (DCDA)

The DCDA device consists of a mainline DCV and a bypass assembly consisting of an approved DCV assembly and water meter. Each device is equipped with test cocks for periodic field testing and is normally supplied with inlet and outlet shut-off valves. For information on operation, installation, trouble shooting & testing refer to Installation Instruction Booklet I476700 furnished with each DCDA unit. For maintenance instructions see pages 4 - 6. For parts list see pages 21 - 24.

III. TROUBLESHOOTING

SYMPTOM	CAUSE	CORRECTIVE ACTION
Check valve fails to hold 1 psid.	<ol style="list-style-type: none"> 1. Shut-off valve not closed completely. 2. Check valve fouled with debris. 3. Check poppet stem not moving freely in guide. 	<ol style="list-style-type: none"> 1. Close #2 shut-off valve or inspect for possible through leakage. 2. Inspect and clean seat disc and seat. 3. Inspect for debris or deposit on poppet stem or guide.

IV. MAINTENANCE INSTRUCTIONS - 1/2" (40-103)

A. DISASSEMBLY – CHECK VALVES

1. Close #2 shut-off valve, then close #1 shut-off valve.
2. Bleed pressure from the assembly by opening #2, #3, and #4 test cocks.

CAUTION: Caps are spring loaded and should be removed carefully to avoid personal injury.

3. Unscrew cap using hex head provided.
4. Remove spring and poppet assembly from the body.
5. Remove the seat disc from the poppet.

B. INSPECTION

1. All parts should be carefully inspected for any damage or excessive wear and thoroughly rinsed in clean water prior to reassembly. Replace worn parts as necessary.

C. ASSEMBLY – CHECK VALVE POPPET

1. Install new disc in poppet.

NOTE: Due to the symmetry of the seat disc, the old disc may be turned over to obtain an effective seal.

C. ASSEMBLY – CHECK VALVE

1. Install the poppet assembly into the body.
2. Install the spring onto the poppet.
3. Apply a thin coat of FDA approved lubricant on cap o-ring.
4. Guide cap over spring and poppet stem and tighten cap.

V. MAINTENANCE INSTRUCTIONS - 1/2" (4S-103)

A. DISASSEMBLY

1. Close inlet and outlet shut-off valves
2. Bleed pressure from the assembly by opening #2, #3, and #4 test cock.
3. Unscrew and remove bronze cap.
4. Remove stainless steel spacer using lifting tab.
5. Remove first check module by pulling outward with fingers (a small screwdriver may aid removal). Be sure test cock #2 is open so as to prevent hydraulic lock. Generally, the first check o-ring will remain in the bore.
6. Remove second check assembly by sliding the assembly out of its bore (a small screwdriver placed in the groove provided will aid removal). Be sure test cock #4 is open as to prevent hydraulic lock.

B. INSPECTION

7. All parts should be carefully inspected for any damage or excessive wear and thoroughly rinsed in clean water prior to reassembly.
8. Replace all worn parts as necessary.

NOTE: Check valve modules are not user serviceable. In the event of check failure, replacement modules are sold individually.

C. ASSEMBLY

1. Replace check modules, second check first then first check. Make sure first check o-ring is installed.

(Tip: push o-ring to the bottom of the bore before installing check module.) Press check module into bore. A thin coat of FDA approved lubricant on o-ring will aid insertion.)

2. Replace stainless steel spacer.
3. Apply a thin coat of FDA approved lubricant on cap o-ring. Replace Cap.

VI. MAINTENANCE INSTRUCTIONS - 3/4" - 2"

A. DISASSEMBLY — CHECK VALVES

1. Close #2 shut off valve, then close #1 shut-off valve.
2. Bleed pressure from the assembly by opening #2, #3 and #4 test cock.

CAUTION: Caps are spring loaded and should be removed carefully to avoid personal injury.

3. Unscrew cap using hex head provided.
4. Remove spring and poppet assembly from the body.

B. DISASSEMBLY — CHECK VALVE POPPET

CAUTION: Do not use pliers or other tools which may damage or scratch the plastic stem.

1. Holding the poppet assembly in one hand, remove screw and retaining washer.
2. Remove the seat disc.
3. All parts should be carefully inspected for any damage or excessive wear and thoroughly rinsed in clean water prior to reassembly. Replace worn parts as necessary.

C. ASSEMBLY — CHECK VALVE POPPET

1. Install new disc in poppet and secure with washer and screw.

D. ASSEMBLY — CHECK VALVE

1. Place and center the poppet assembly in the body.
2. Install the spring onto the poppet.
3. Apply a thin coat of FDA approved lubricant on cap o-ring.
4. Guide cap over spring and poppet stem and tighten cap.

VII. MAINTENANCE INSTRUCTIONS - 2-1/2" - 10"

A. DISASSEMBLY — CHECK VALVES

1. Close #2 shut-off valve, then close #1 shut-off valve.
2. Bleed pressure from the assembly by opening #2, #3, and #4 test cock.
3. Remove cover bolts and cover.

NOTE: The spring load on the cover will be removed when the cover bolts are backed off approximately 3/8".

4. Remove the complete check assembly straight out of the valve body being careful not to damage the seat ring.
5. The check valve seat is threaded into the body and may be removed at this time if necessary (The seat is bolted into the body on the 10" unit).
6. To remove the seat disc, remove the retaining plate nut (On the 8" & 10" units remove the retaining plate bolts) and retaining plate, remove disc.

WARNING: The check valve spring is held in compression by the stem nut on top. This nut should not be removed unless the spring requires replacement.

B. ASSEMBLY — CHECK VALVES

1. Install seat disc in holder and secure with retaining plate and retaining nut or bolts as applicable.

NOTE: Due to the symmetry of the disc, the old disc may be turned over to obtain an effective seal.

2. Install the check valve assembly into the body.
3. Install the check valve cover and tighten bolts evenly.

VIII. TESTING PROCEDURES

NOTE: It is important that the DCV device be tested periodically in compliance with local codes, but at least once a year or more, as service conditions warrant.

METHOD 1 (DUPLEX GAUGE)

NOTE: Test set-up is illustrated in Figure 6 for 1/2" through 2" and Figure 7 for 2-1/2 through 10".

EQUIPMENT REQUIRED:

Double check backflow preventer test kit.

NOTE: All connections must be free from leaks in order to achieve accurate readings during testing.

TEST NO. 1:

PURPOSE: TO TEST CHECK VALVE #1 FOR TIGHTNESS AGAINST REVERSE FLOW.

REQUIREMENT:

The valve shall permit no through leakage in a direction reverse normal flow under all conditions of a pressure differential.

PROCEDURE:

1. Bleed water through all four test cocks to flush any foreign material.
2. Connect the "high" side hose to test cock #2. Connect the "low" side hose to test cock #3.
3. Open test cocks #2 and #3. Bleed both hoses, making sure to bleed the low side last.
4. Close #2 shut-off valve, then close #1 shut-off valve.
5. Slowly open by-pass valve #1 and lower the pressure at test cock #2 approximately 2 psi below the pressure at test cock #3. Note: Due to check valve disc compression, both "high" and "low" side gauges may drop at the same rate approximately 10-15 psi or more. After the check valve disc compresses fully the required "high" side pressure of 2 psi below the "low" side should be obtainable. If this pressure differential can be maintained then check valve #1 is reported as "tight" or "okay". Proceed to test no. 2. However, if this pressure differential cannot be maintained proceed to step no. 6.
6. Open #1 shut-off valve to repressurize the device.
7. Loosely attach the vent hose to test cock #1. Bleed all air from the gauge and vent hose by opening bypass valve #2. Close by-pass valve #2, tighten vent hose. Open test cock #1.
8. Close #1 shut-off valve.
9. Loosen the "low" side hose at test cock #3 and lower the pressure in the assembly approximately 10 psi. Retighten hose.
10. Simultaneously open by-pass valves #1 and #2 very slowly. If the check valve is holding tight the "high" side gauge will begin to drop while the "low" side gauge will rise. Close both bypass valves. If a small (no more than 5 psi) pressure differential is created and held, then the check valve is reported as "tight" or "okay." If a pressure differential cannot be maintained the check valve is reported as leaking.

TEST NO. 2:

PURPOSE: TO TEST CHECK VALVE #2 FOR TIGHTNESS AGAINST REVERSE FLOW.

REQUIREMENT:

The valve shall permit no through leakage in a direction reverse to normal flow under all conditions of a pressure differential.

PROCEDURE:

1. Same as test #1 except the "high" side hose is connected to test cock #3 and the "low" side connected to test cock #4.

RESTORE OPERATION:

1. Close all test cocks. Remove testing equipment. Open shut-off valves #1 and #2.

VIII. TESTING PROCEDURES

FIGURE 6

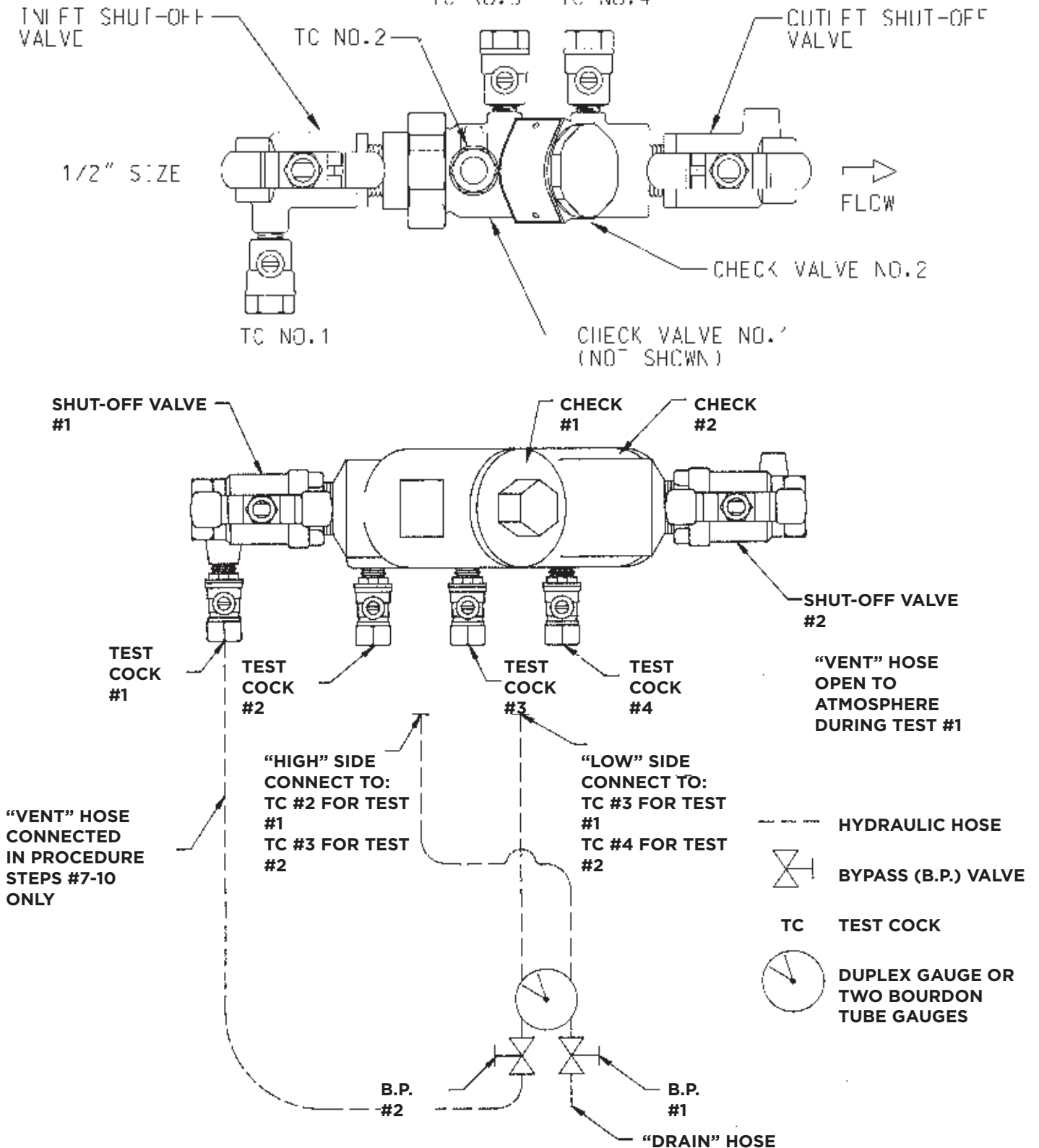

VIII. TESTING PROCEDURES

FIGURE 7

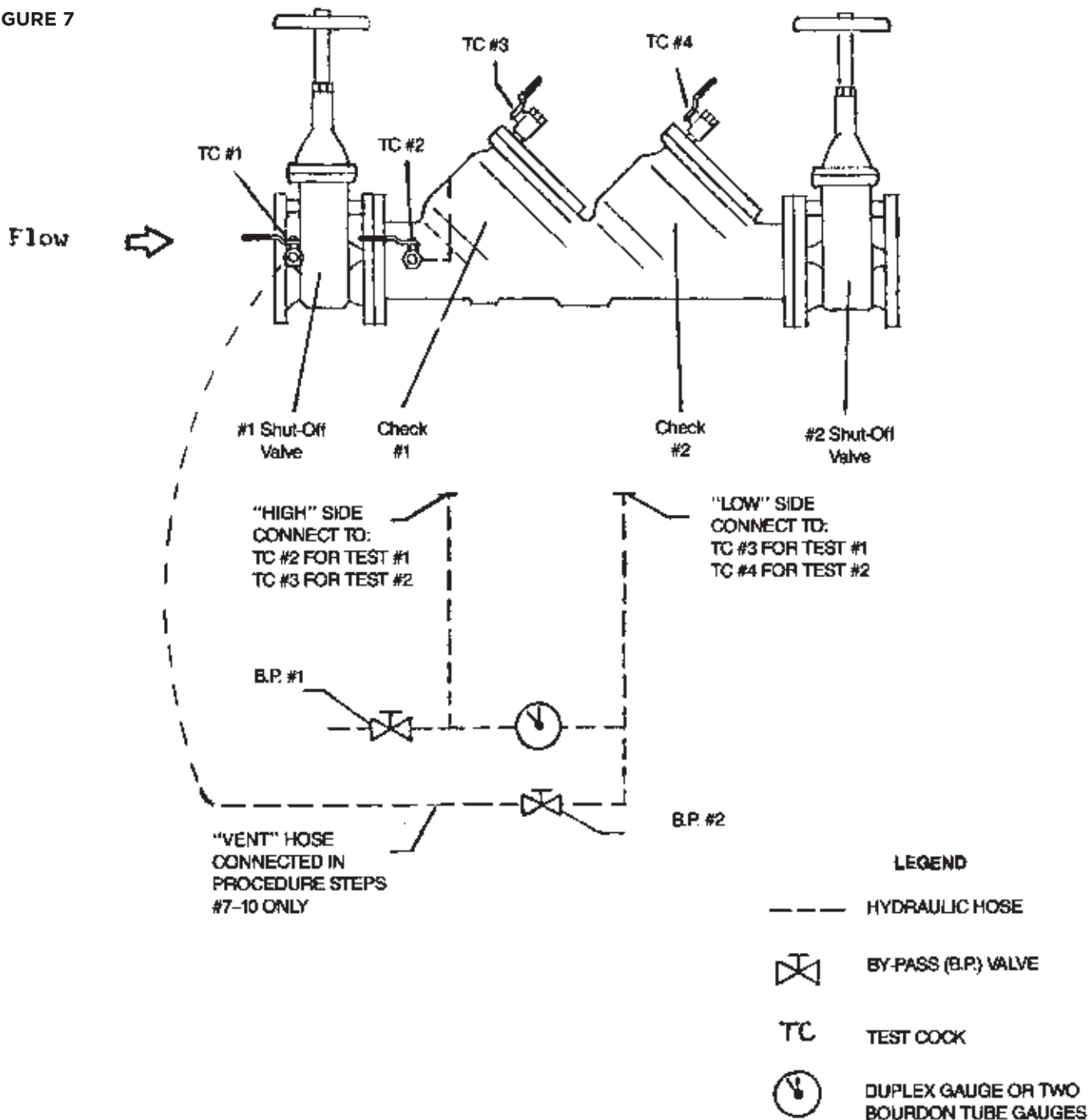

VIII. TESTING PROCEDURES

NOTE: Test set-up is illustrated in Figure 8 for 1/2" through 2" and Figure 9 for 2-1/2 through 10".

EQUIPMENT REQUIRED:

Differential pressure gauge type test kit such as Model No. 40-200-TKU or 40-200-TK5U.

NOTE: For all testing, the gauge and open ends of hoses not being used must be held at the same level as the assembly being tested.

TEST NO. 1:

PURPOSE: TO DETERMINE THE STATIC PRESSURE DROP ACROSS CHECK VALVE NO. 1.

REQUIREMENT:

The static pressure drop across check valve No. 1 shall be at least 1 psid.

PROCEDURE:

1. To eliminate foreign material, flush all four test cocks, one at a time.
2. Open test valves No. 1 and No. 2 on the gauge and close test valve No. 3. Attach "high" side hose to test cock No. 2.
3. Bleed all air from hose and gauge by slowly opening test cock No.2. Then slowly close test valve No. 2.
4. Close the outlet shut-off valve. Then close the inlet shut-off valve.
5. Slowly open test cock No. 3. After the gauge reading stabilizes and water stops running out of test cock No. 3, the static pressure drop across the check valve indicated by the gauge and is recorded as such.

NOTE: If water continues to discharge from test cock No. 3 then a leaky shut-off valve is evident and should be repaired or bypassed before testing continues. If the water recedes from the test cock opening then move the gauge to a point level with the centerline of the check seat area and record the gauge reading as the static pressure differential across check No. 1.

TEST NO. 2:

PURPOSE: TO DETERMINE THE STATIC PRESSURE DROP ACROSS CHECK VALVE NO. 2.

REQUIREMENT:

The static pressure drop across check valve No. 2 shall be at least 1 psid.

PROCEDURE:

1. Open test valves No. 1 and No. 2 on the gauge and close test valve No. 3. Attach "high" side hose to test cock No. 3.
2. Bleed all air from hose and gauge by slowly opening test cock No. 3. Then slowly close test valve No. 2.
3. Close the outlet shut-off valve. Then close the inlet shut-off valve.
4. Slowly open test cock No. 4. After the gauge reading stabilizes and water stops running out of test cock No. 4, the static pressure drop across the check valve is indicated by the gauge and is recorded as such.

NOTE: If water continues to discharge from test cock No. 4 then a leaky shut-off valve is evident and should be repaired or bypassed before testing continues. If the water recedes from the test cock opening then move the gauge to a point level with the centerline of the check seat area and record the gauge reading as the static pressure differential across check No. 2.

VIII. TESTING PROCEDURES

FIGURE 9

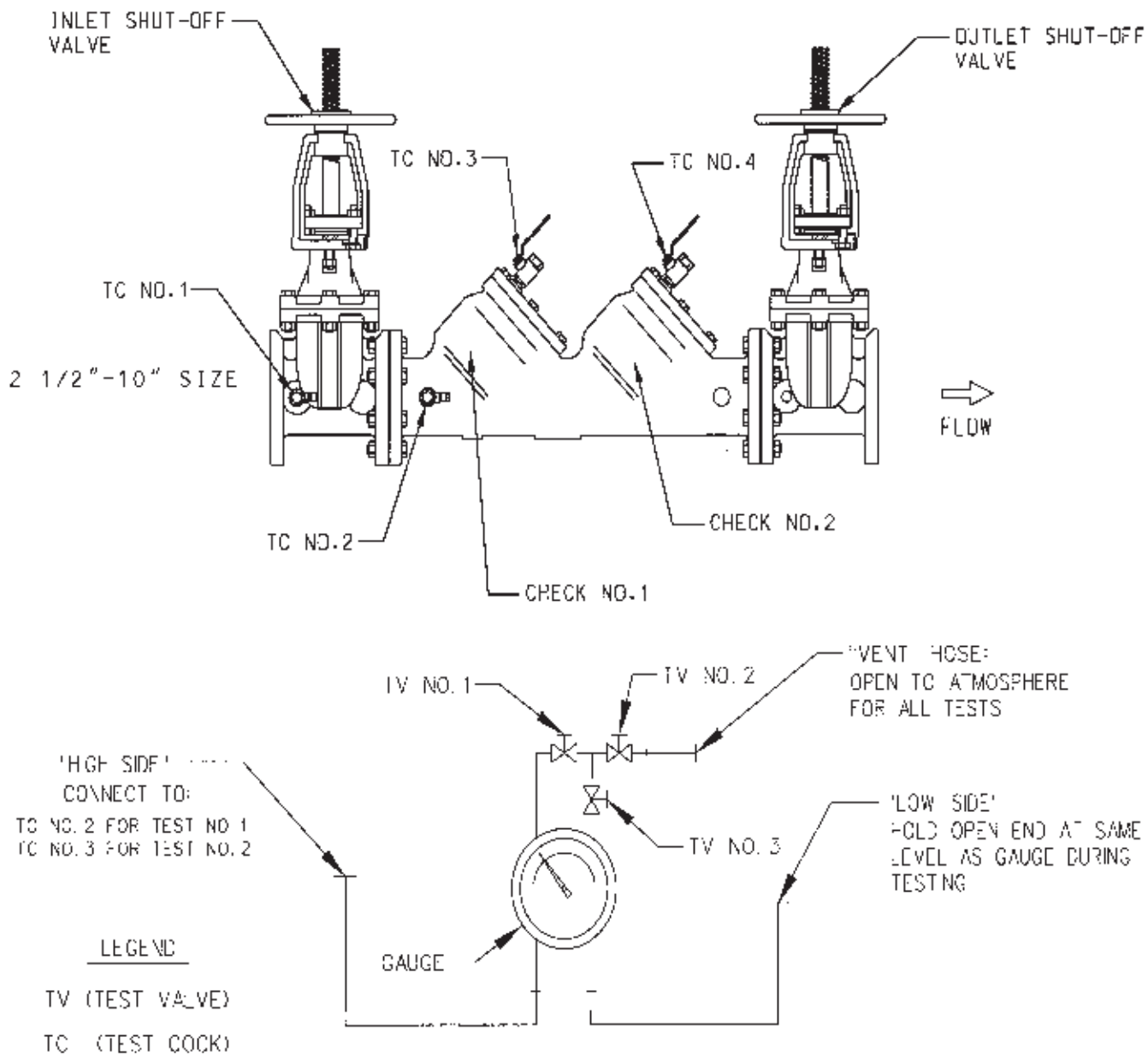

VIII. TESTING PROCEDURES

FIGURE 6

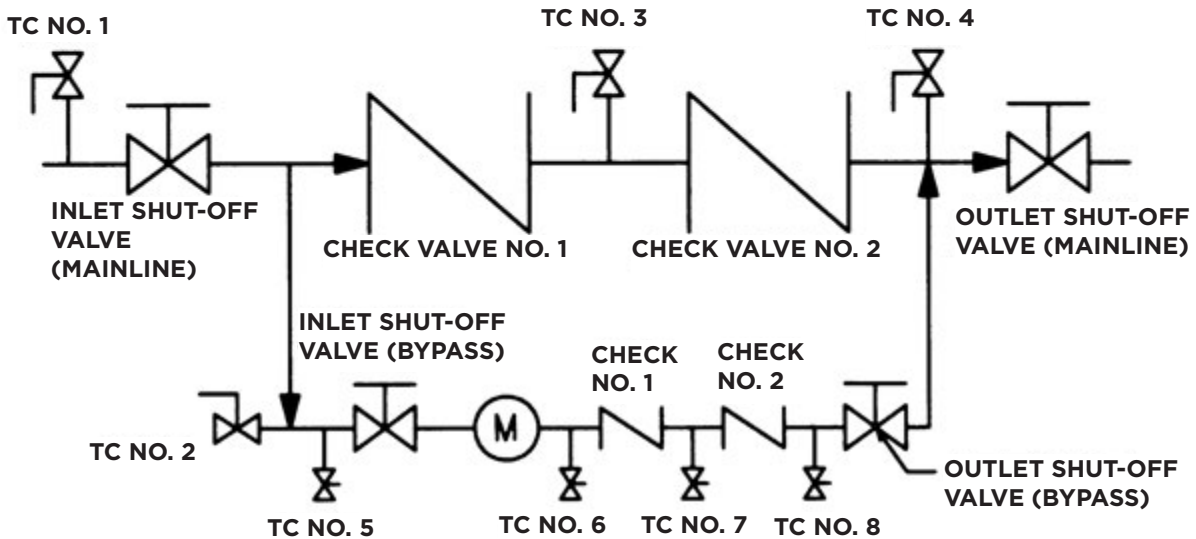
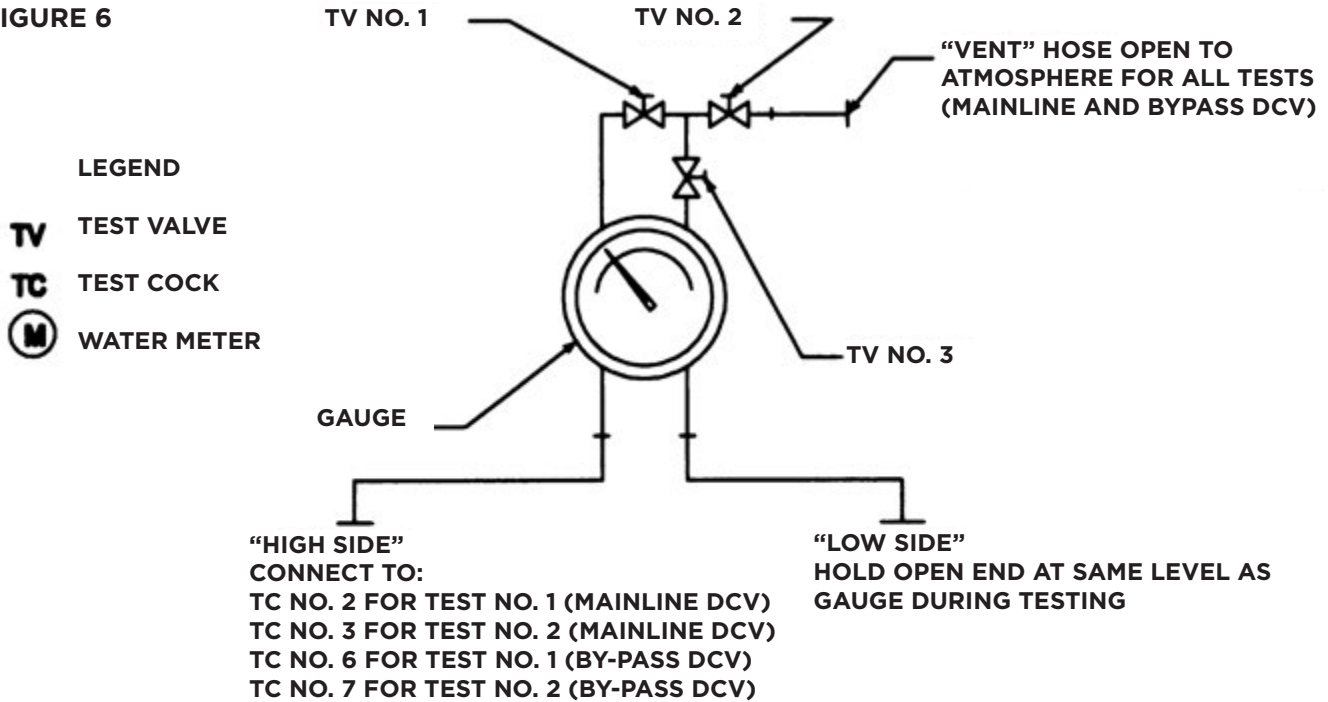

VIII. TROUBLESHOOTING

SYMPTOM	CAUSE	CORRECTIVE ACTION
Check valve fails to hold 1 psid.	<ol style="list-style-type: none"> 1. Shut-off valve not closed completely. 2. Check valve fouled with debris. 	<ol style="list-style-type: none"> 1. Close outlet shut-off valve or inspect for possible through leakage. 2. Inspect and clean seat disc and seat.

PARS LIST - 1/2" BRONZE

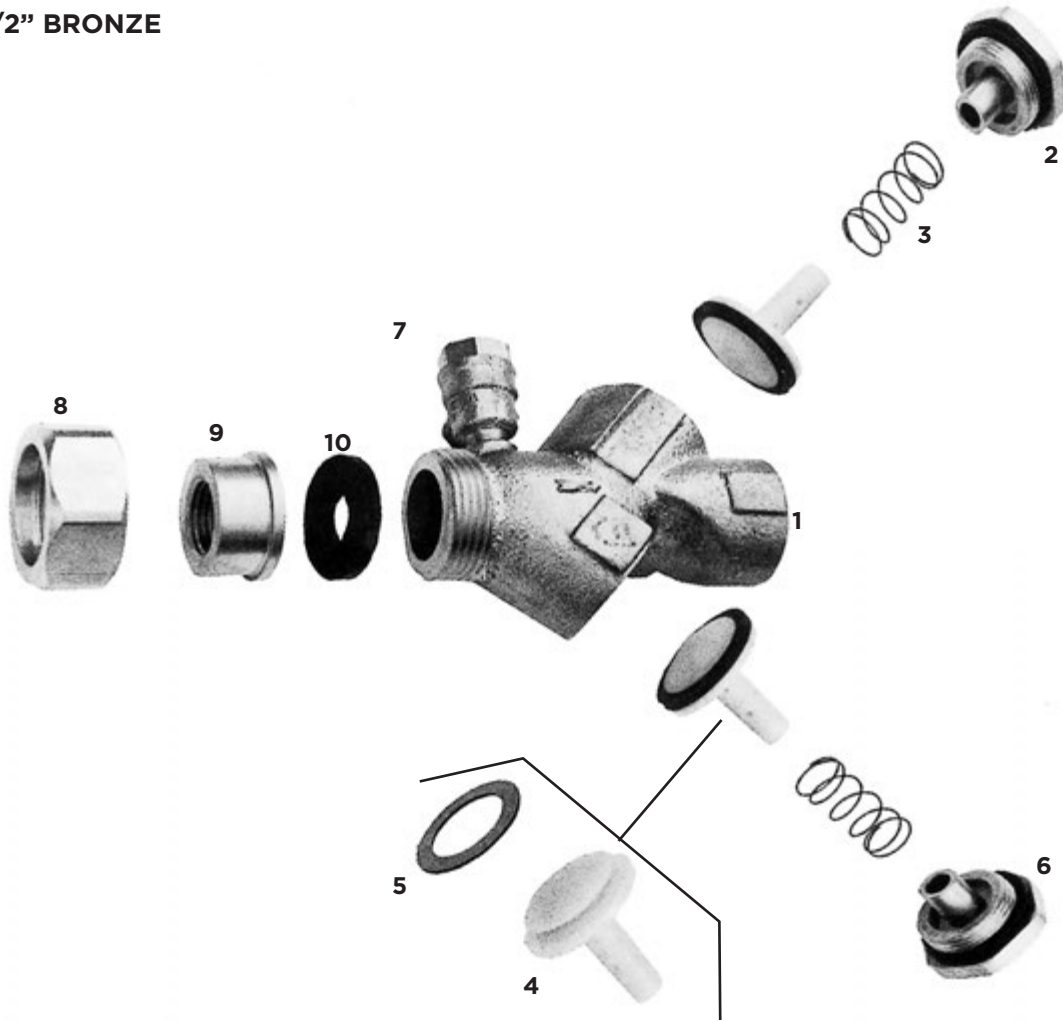

ITEM NO.	DESCRIPTION	QTY	PART NO.
1	Body	1	Consult Factory
2	Cap	2	F-3009-06
3	Spring	2	A-1750-00
4	Poppet	2	K-3404-00
5	Seat Disc	2	D-2600-00
6	Cap O-Ring	2	D-2501-00
7	Test Cock	3	78-257-01
8	Union Nut	1	C-1778-06
9	Tail Piece	1	L-5226-06
10	Seal	1	D-2607-00

REPAIRS KITS

MAJOR REPAIR KIT

40-300-02: Kit includes items (3 (2), 6 (2), part no. W-6759-06 (2)), n/s packet lube

RUBBER REPAIR KIT

40-300-01: Kit includes items (5 (2), 6 (2)), n/s packet lube

PARTS LIST - 1/2" 4S-103 DOUBLE CHECK VALVE

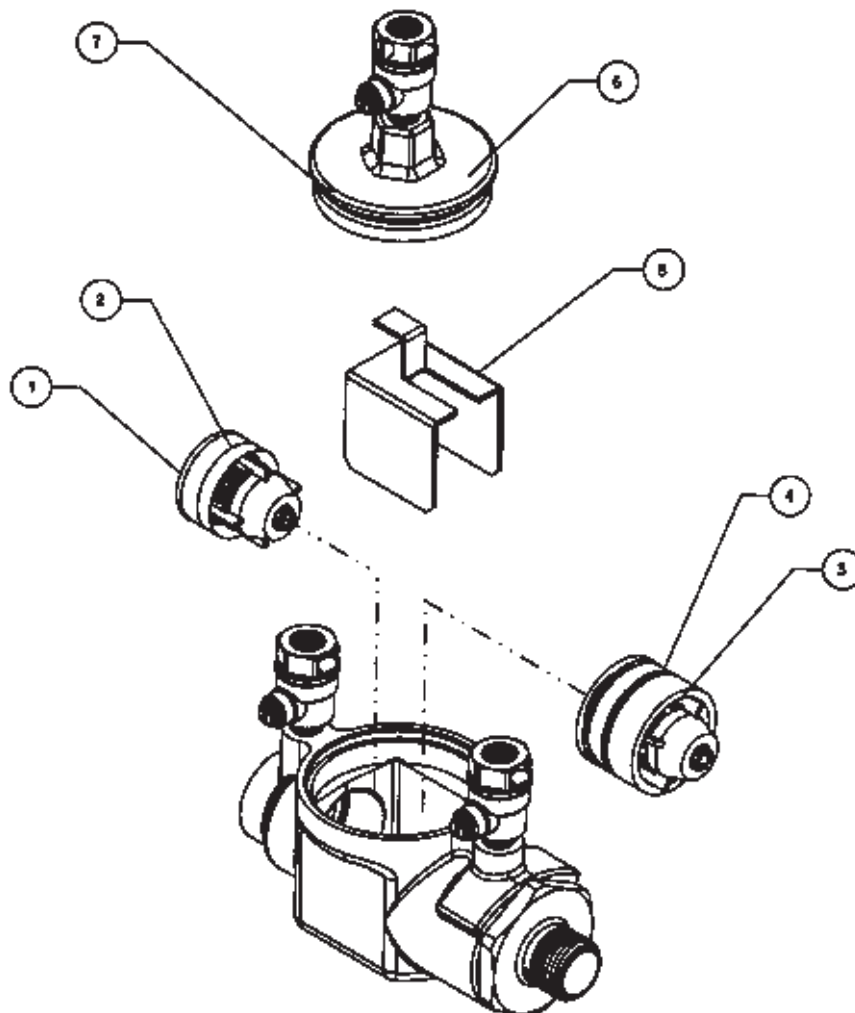

ITEM NO.	DESCRIPTION	QTY	PART NO.
1	Check Module O-Ring	1	D-3885-00
2	1st Check Module	1	F-3228-00
3	2nd Check Assembly	1	W-4302-00
4	2nd Check O-Ring	1	D-2422-00
5	Check Spacer	1	L-6104-00
6	Cap	1	F-3206-05
7	Cap O-Ring	1	D-2568-00

REPAIRS KITS

4S-003-01: Kit includes items 1, 2, 3, 4, 7, n/s packet lube

INLET AND OUTLET SHUT-OFF VALVES

VALVE TYPE	1/2"
Inlet Shut-Off Valve	7B80301
Inlet Shut-Off Valve w/ Union	7B30301
Outlet Shut-Off Valve	7B80331
Outlet Shut-Off Valve w/ Union	7B30331
Replacement Handles for Shut-Off Valves	W858800

PART NUMBER DIAGRAM - 3/4" - 2" (BRONZE) TOP ENTRY

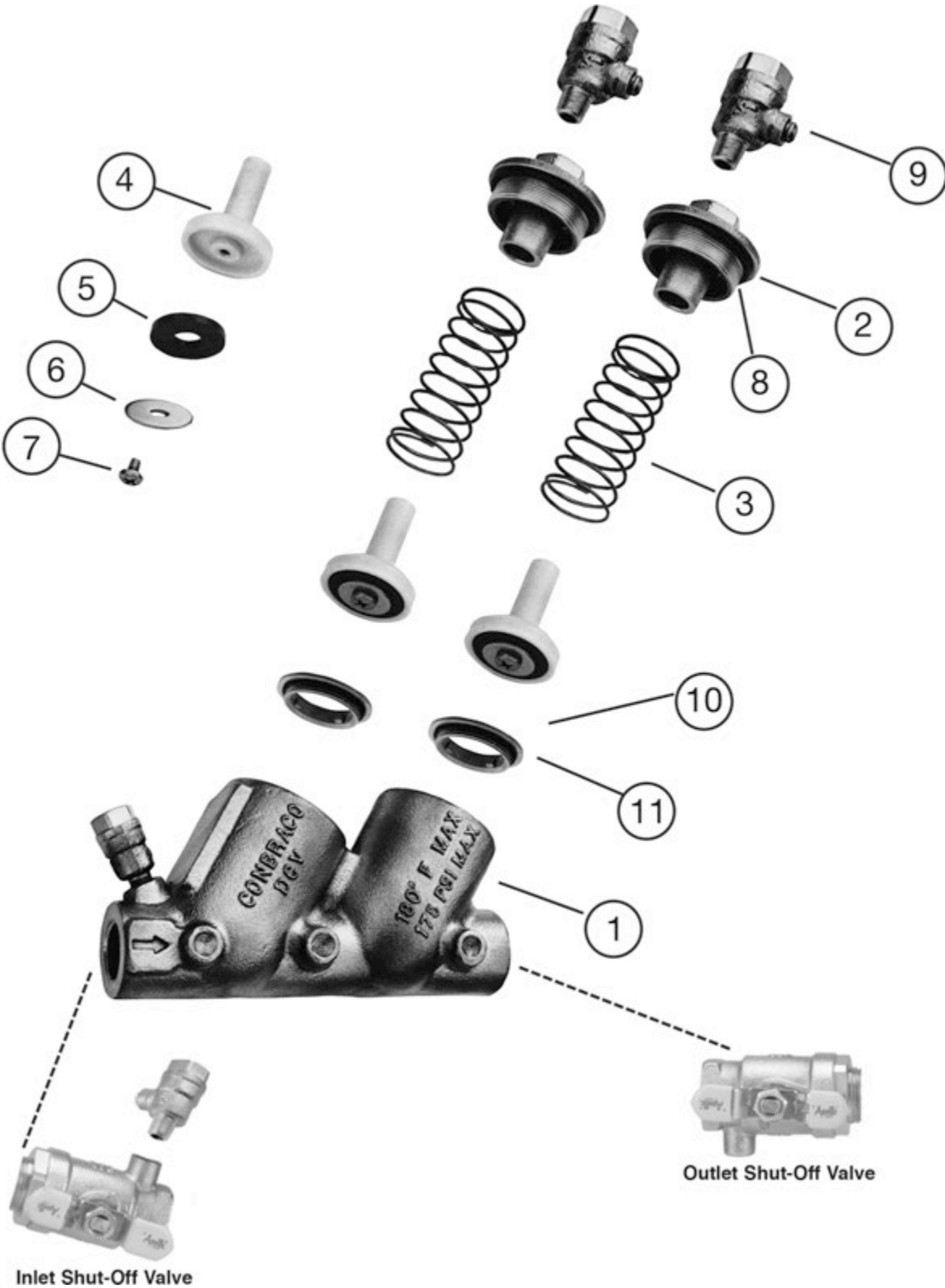

PARTS LIST - 3/4" - 2" (BRONZE) TOP ENTRY

40-100-T SERIES TOP ENTRY DOUBLE CHECK VALVE ASSEMBLY

ITEM NO.	DESCRIPTION	QUANTITY	PART NO.	
			3/4", 1"	1-1/4", 1-1/2", 2"
1	Body	1	Consult Factory	Consult Factory
2	Cap	2	F-3108-05	F-3115-05
3	Spring	2	A-1700-00	A-1701-00
4	Poppet	2	K-3362-00	K-3367-00
5	Seat Disc	2	D-2503-00	D-2508-00
6	Seat Retainer	2	D-2499-00	D-2509-00
7	Screw	2	B-1750-00	B-1750-00
8	Cap O-Ring	2	D-2500-00	D-2510-00
9	Test Cock	4	78-290-01	78-291-01
10	Check Seat	2	L-4864-00	L-4866-00
11	Check O-Ring	2	D-2274-00	D-2565-00
11	Check O-Ring	2	D-227400	D-256500

* 1/8" NPT plug needed for units without top mounted test cocks.

** 1/4" NPT plug needed for units without top mounted test cocks.

REPAIR KITS

KIT	PARTS INCLUDED	PART NO	
		3/4", 1"	1-1/4", 1-1/2", 2"
Major Repair Kit	(4 (2), 5 (2), 6 (2), 7 (2), 8 (2), 10 (2), 11 (2)), n/s packet lube	40-004-A5	40-007-A5
Check Valve Repair Kit	(4, 5, 6, 7, 8, 10, 11), n/s packet lube	40-004-A2	40-007-A2
Rubber Repair Kit	(5 (2), 8 (2), 11 (2)), n/s packet lube	40-004-A6	40-007-A6
Replaceable Seat Kit	(10 (2), 11 (2)), n/s packet lube	40-004-A8	40-007-A8

INLET AND OUTLET SHUT-OFF VALVES 40-10X-T

VALVE TYPE	PART NO				
	3/4"	1"	1-1/4"	1-1/2"	2"
Inlet Shut-Off Valve	7B80401	7B80501	7B80699A	7B80799A	7B80899A
Inlet Shut-Off Valve w/ Union	7B30401	7B30501	7B30699A	7B30799A	7B30899A
Outlet Shut-Off Valve	7B80431	7B80531	7B80699B	7B80799B	7B80899B
Outlet Shut-Off Valve w/ Union	7B30431	7B30531	7B30699B	7B30799B	7B30899B
Replacement Handles for Shut-Off Valves	W858800	W859100	W891500	W891600	W891600

PARTS NUMBER DIAGRAM - 2-1/2" - 10" (DUCTILE IRON)

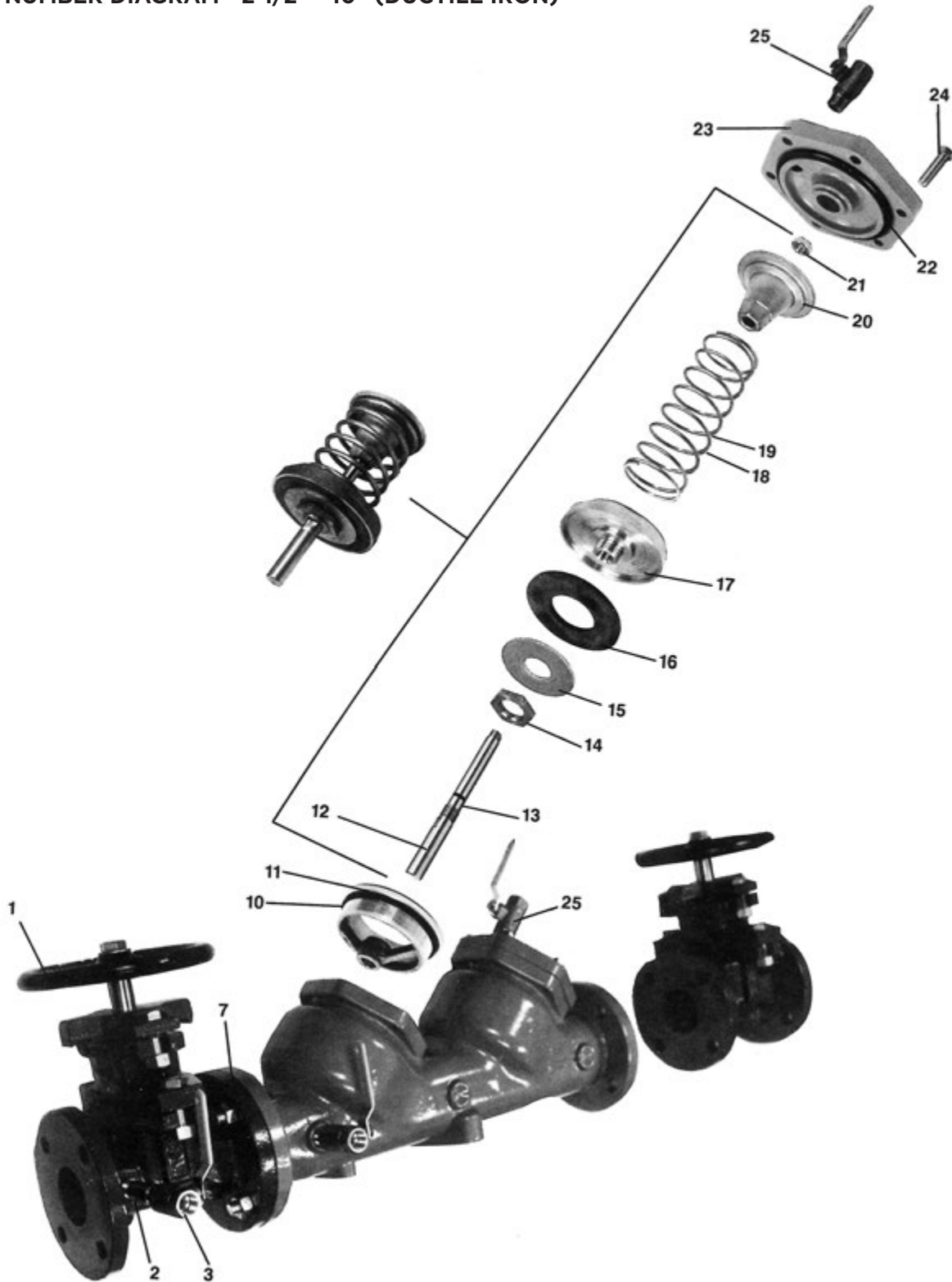

PARTS LIST - 2-1/2" - 10" (DUCTILE IRON)

ITEM NO.	DESCRIPTION	QUANTITY	PART NO.		
			2-1/2"	3"	4"
1	Shut-Off Valve (OS&Y)	2	W-6789-00	W-6790-00	W-6824-00
1	Shut-Off Valve (NRS)	2	W-6785-00	W-6786-00	W-6743-00
1	Shut-Off Valve (Ball)	2	6Q-209-01	6Q-200-01	6Q-20A-01
2	Brass Nipple	1	K-3406-00	K-3406-00	K-3406-00
3	Test Cock	1	70-103-01	70-103-01	70-103-01
7	Body	1	Q-4526-19	Q-4527-19	Q-4534-19
10	C.V. Seat O-Ring	2	D-2576-00	D-2567-00	D-2573-00
11	C.V. Seat	2	L-4637-05	L-4637-05	L-4640-05
12	C.V. Stem	2	G-3239-06	G-3239-00	G-3242-00
13	C.V. Stem O-Ring	2	D-2561-00	D-2561-00	D-2561-00
14	Retainer Nut	2	C-1756-00	C-1756-00	C-1756-00
15	Retainer Washer	2	E-2199-00	E-2199-00	E-2204-00
16	C.V. Seat Disc	2	D-2560-00	D-2560-00	D-2572-00
17	Seat Disc Holder	2	F-3000-05	F-3000-05	F-3001-05
18	1st Check Spring	1	A-1741-00	A-1741-00	A-1744-00
19	2nd Check Spring	1	A-1741-00	A-1741-00	A-1744-00
20	Spring Retainer	2	E-2198-05	E-2198-05	E-2202-05
21	Jam Nut	2	C-1589-05	C-1589-05	C-1589-05
22	Cap O-Ring	2	D-2566-00	D-2566-00	D-2574-00
23	C.V. Cap	2	Q-4530-19	Q-4530-19	Q-4533-19
24	Cap Bolt	12	B-1797-00	B-1797-00	B-1801-00
25	Test Cock	3	70-803-10	70-803-10	70-803-10

REPAIR KITS

KIT	PARTS INCLUDED	PART NO.		
		2-1/2"	3"	4"
1st Check Valve Repair Kit	(12, 13, 14, 15, 16, 17, 18, 20, 21, 22), n/s packet lube	40-009-02	40-009-02	40-00A-02
Seal Repair Kit	(10, 11, 22), n/s packet lube	40-009-03	40-009-03	40-00A-03
Rubber Repair Kit	2 each (10, 13, 16, 22), n/s packet lube	40-009-04	40-009-04	40-00A-04

PARTS NUMBER DIAGRAM - 6" / 8" / 10" DCV

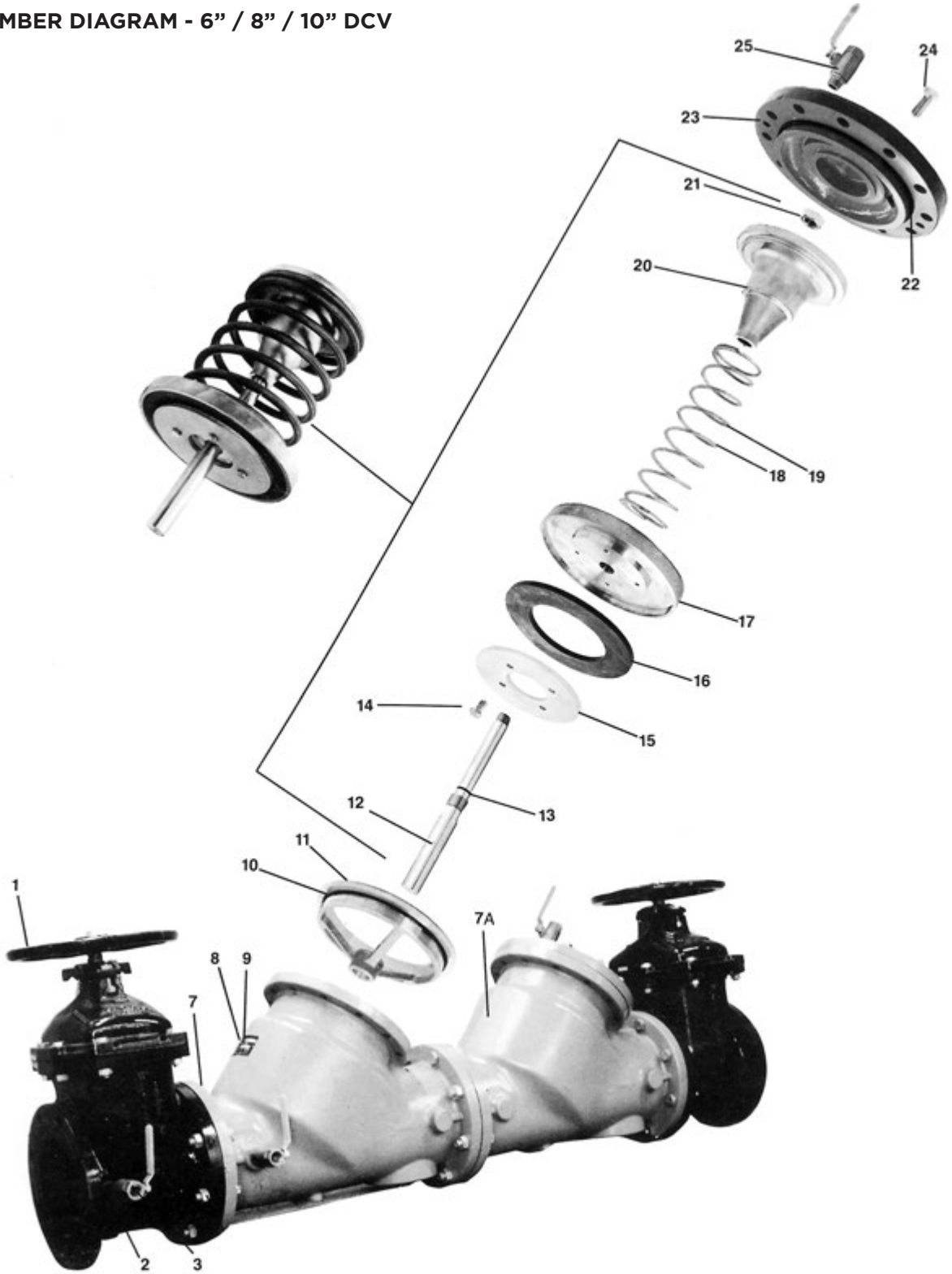

PARTS LIST - 6" / 8" / 10" DCV

40-100 DOUBLE CHECK BACKFLOW PREVENTER

ITEM NO.	DESCRIPTION	QUANTITY	PART NO.		
			2-1/2"	3"	4"
1	Shut-Off Valve (OS&Y)	2	W-6825-00	W-6826-00	W-6859-00
1	Shut-Off Valve (NRS)	2	W-6744-00	W-6827-00	W-6858-00
1	Shut-Off Valve (Ball)	2	6Q-20C-01	6Q-20E-01	N/A
2	Brass Nipple	1	K-3412-40	K-3412-00	K-3412-00
3	Test Cock	1	70-104-10	70-104-10	70-104-10
6A	Stud	2	N/A	N/A	B-2036-00
7	Body	1	Consult Factory	Consult Factory	Consult Factory
7A	Body	1	Consult Factory	Consult Factory	Consult Factory
10	C.V. Seat O-Ring	2	D-2576-00	D-2589-00	D-2588-00
11	C.V. Seat	2	L-4644-05	L-4653-05	L-4759-05
12	C.V. Stem	2	G-3246-00	G-3273-00	G-3305-00
13	C.V. Stem O-Ring	2	D-2578-00	D-2587-00	D-2587-00
14	Retainer Nut/Bolt	***	C-1760-00	B-1754-00	B-1754-00
15	Retainer Washer	2	E-2205-00	E-2208-00	E-2229-00
16	C.V. Seat Disc	2	D-2575-00	D-2586-00	D-2649-00
17	Seat Disc Holder	2	F-3002-05	F-3008-05	F-3019-05
18	1st Check Spring	1	A-1746-00	A-1748-00	A-1779-00
19	2nd Check Spring	1	A-1746-00	A-1748-00	A-1779-00
20	Spring Retainer	2	E-2203-05	E-2207-05	E-2228-05
21	Jam Nut	2	C-1706-00	C-1763-00	C-1763-00
22	Cap O-Ring	2	D-2577-00	D-2588-00	D-2651-00
23	C.V. Cap	2	Q-4537-19	Q-4545-19	Q-4574-19
24	Cap Bolt	****	B-1800-00	B-1690-00	B-1881-00
25	Test Cock	3	70-804-10	70-804-10	70-804-10
N/S	Seat Bolt	12	N/A	N/A	B184900

*** 6" QTY = 2 / 8" & 10" QTY = 8
**** 6" QTY = 12 / 8" & 10" QTY = 24

REPAIR KITS

KIT	PARTS INCLUDED	PART NO.		
		2-1/2"	3"	4"
1st Check Valve Repair Kit	(12, 13, 14, 15, 16, 17, 18, 20, 21, 22), n/s packet lube	40-009-02	40-009-02	40-00A-02
Seal Repair Kit	(10, 11, 22), n/s packet lube	40-009-03	40-009-03	40-00A-03
Rubber Repair Kit	2 each (10, 13, 16, 22), n/s packet lube	40-009-04	40-009-04	40-00A-04

PART NUMBER DIAGRAM - 3" - 4" DCDA

NOTES

- USE P/N W-7062-00 FOR METER IN CUBIC FEET REGISTER.
- USE P/N W-7094-00 FOR METER IN GALLONS REGISTER.
- N/S - NOT SHOWN

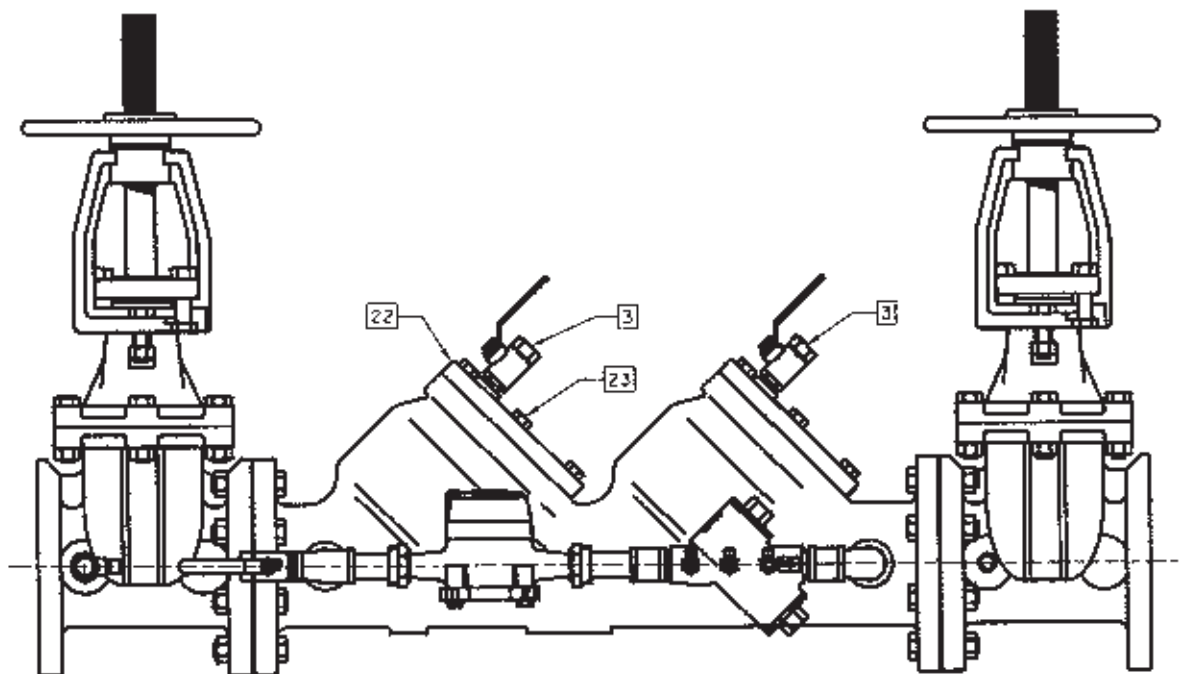
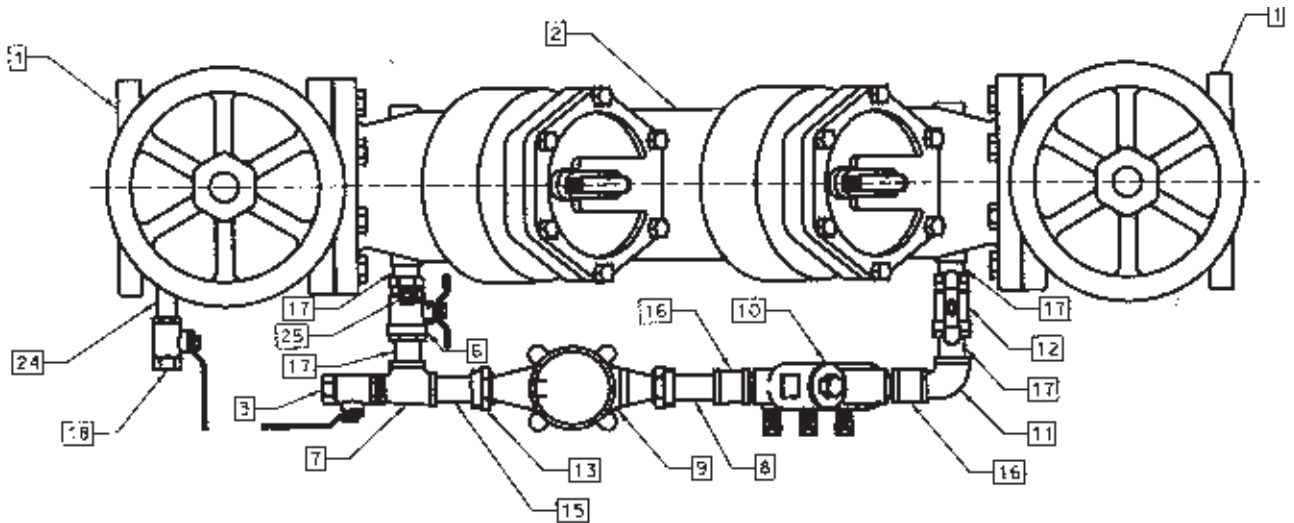

PARTS LIST - 3" - 4" DCDA

ITEM NO	DESCRIPTION	QUANTITY	PART NO	
			3"	4"
1	Gate Valve (OS&Y)	2	W679000	W682400
2	DCDA Body	1	Contact Factory	Contact Factory
3	Test Cock	3	7080310	7080310
N/S	1st Chk Poppet Ass'y	1	W710705	W710005
N/S	2nd Chk Poppet Ass'y	1	W671805	W673105
6	By-Pass Shut-Off Valve	1	7B10401	7B10401
7	Tee, Reducing	1	K350600	K350600
8	Coupling, Water Meter	1	K350500	K350500
9	Water Meter in Cubic Feet	1	W706200	W706200
9	Water Meter in Gallons	1	W709400	W709400
10	3/4" DCV	1	W378905	W738905
11	Elbow, Street	*	K350200	K350200
12	By-Pass Shut-Off Valve	1	7B10431	7B10431
13	Swivel Nut	1	N/A	C186705
N/S	Washer, Meter	1	N/A	D261000
15	Coupling	1	N/A	K379106
16	3/4" Coupling	2	N/A	K350400
17	Nipple, Close	**	K337000	K337000
18	Test Cock	1	7010310	7010310
22	Cap	2	Q453019	Q453319
23	Cap Bolt	12	B179700	B180100
24	Nipple	1	K340600	K340600
25	Test Cock	1	7825701	7825701
N/S	Nipple, 3/4" x 3" Lg.	2	K341200	N/A
N/S	Elbow, 3/4" - 90°	1	K350100	N/A
N/S	Cap O-Ring	2	D256600	D257400
N/S	Seat O-Ring	2	D256700	D257300
N/S	Plug, 1/2"	1	K300800	K300800
N/S	Check Valve Seat	2	L463705	L46400

* 3" QTY = 3 / 4" QTY = 1

** 3" QTY = 2 / 4" QTY = 4

PART NUMBER DIAGRAM - 6" / 8" / 10" DCDA

NOTES

- USE P/N W-7062-00 FOR METER IN CUBIC FEET REGISTER.
- USE P/N W-7094-00 FOR METER IN GALLONS REGISTER.
- N/S - NOT SHOWN

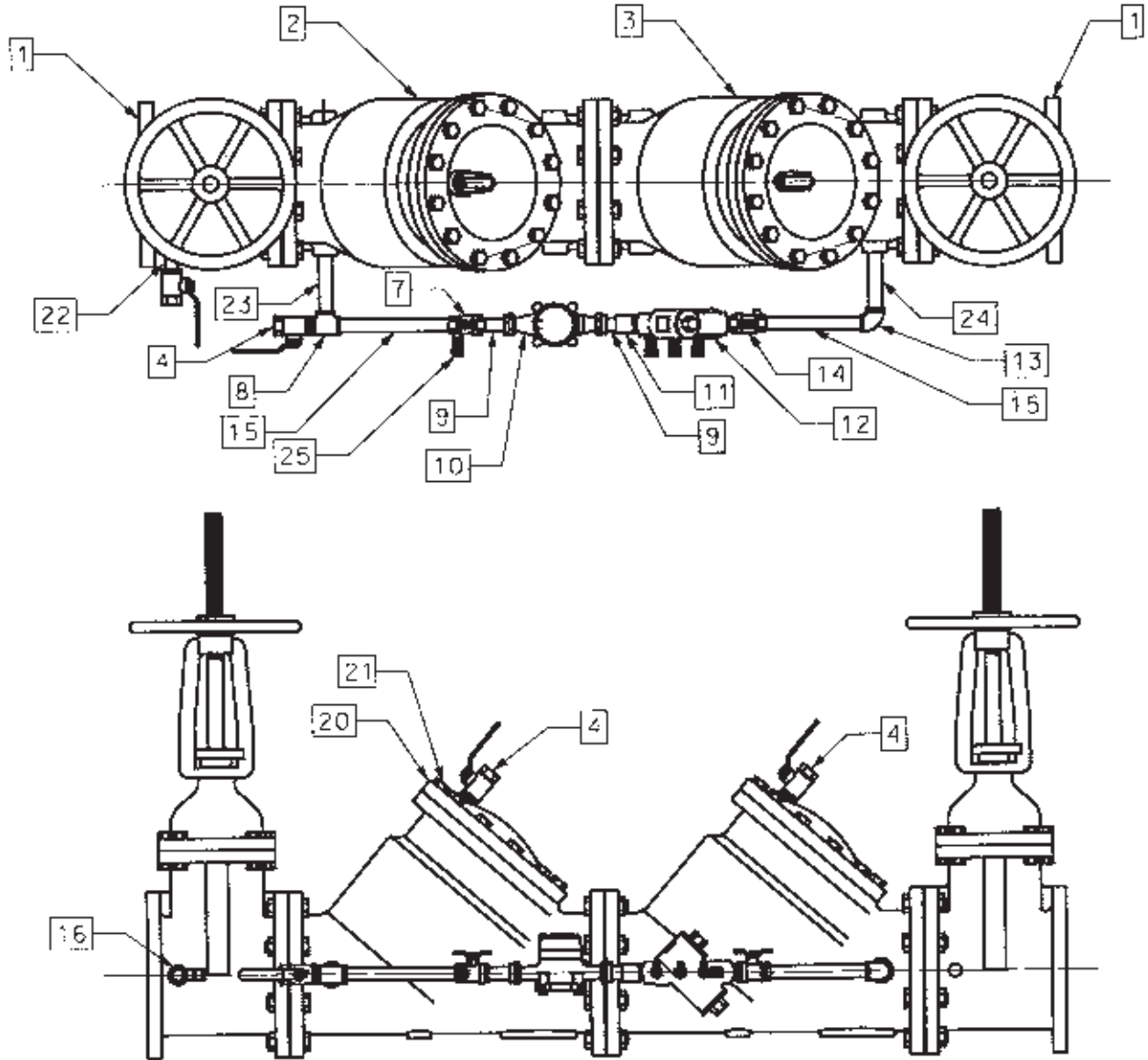

PARTS LIST - 6" / 8" / 10" DCDA

ITEM NO	DESCRIPTION	QUANTITY	PART NO		
			6"	8"	10"
1	Gate Valve (OS&Y)	2	W682500	W682600	W685900
2	Body (1st Check)	1	Contact Factory	Contact Factory	Contact Factory
3	Body (2nd Check)	1	Contact Factory	Contact Factory	Contact Factory
4	Ball Valve	3	7080410	7080410	7080410
N/S	1st Chk Poppet Ass'y	1	W706605	W708505	W711305
N/S	2nd Chk Poppet Ass'y	1	W674205	W674605	W685705
7	By-Pass Shut-Off Valve	1	7B10401	7B10401	7B10401
8	Tee, 3/4" NPT	1	K351100	K351100	K351100
9	Coupling, Water Meter	2	K350500	K350500	K350500
10	Water Meter in Cubic Feet	1	W706200	W706200	W706200
10	Water Meter in Gallons	1	W709400	W709400	W709400
11	Coupling, 3/4"	1	K350400	K350400	K350400
12	3/4" DCV	1	W738905	W738905	W738905
13	Elbow, 3/4" NPT	1	K350100	K350100	K350100
14	By-Pass Shut-Off Valve	1	7B10431	7B10431	7B10431
15	Nipple, 3/4" NPT	2	K350900	K352700	K356000
16	Ball Valve	1	7010410	7010410	7010410
20	Cap	2	Q453719	Q454519	Q457419
21	Cap Bolt	*	B180000	B169000	B188100
22	Nipple, 3/4" NPT	1	K341200	K341200	K341200
23	Nipple, 3/4" x 5-1/2" Lg.	1	K350900	K350900	K350900
24	Nipple, 3/4" NPT	1	K350900	K350900	K355900
25	Test Cock	1	7825701	7825701	7825701
N/S	Elbow, 3/4" - 90°	1	K350100	K350100	K350100
N/S	Cap O-Ring				

* 6" QTY = 12 / 8" & 10" QTY = 24

"Apollo"®

PHONE: (704) 841-6000

FAX: (704) 841-6020

Regional Management List
now available online at:

<http://conbra.co/rmlist>

ES1594 IOM BFMM4001 rev.b 8/17

Customer Service (704) 841-6000
www.apollovalves.com

