

Female NPT Thread, 1/4" to 1" 2000 CWP (psig), 1-1/4" to 2" 1500 CWP (psig), Cold Non-Shock.  
150 psig Saturated Steam.  
Vacuum Service to 29 inches Hg.  
MSS SP-110 Compliant.

### FEATURES

- Fire safe to API 607 (requires -24 suffix)
- Investment cast body
- Reinforced seats and seals
- Blowout-proof stem design
- Zinc Phosphate corrosion protection
- Adjustable packing gland
- Meets NACE MR0175 (2000) & MR0103 (2012) with SS trim
- Compact

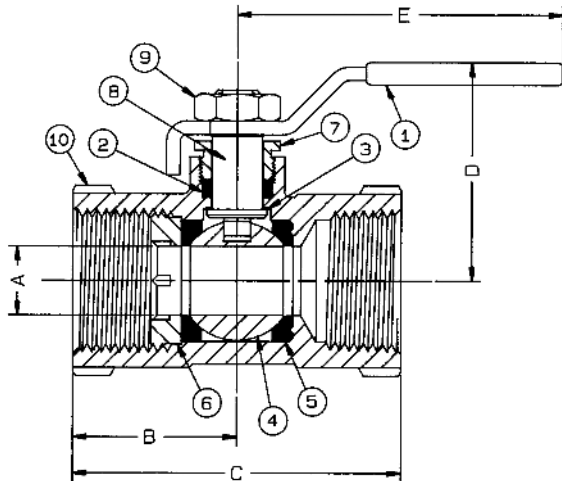

### STANDARD MATERIAL LIST

PART	MATERIAL
1 Lever and grip	Steel, zinc plated w/vinyl
2 Stem packing	MPTFE
3 Stem bearing	RPTFE
4 Ball	ASTM A108, Carbon Steel, Chrome Plated or ASTM A276, Type 316 Stainless Steel
5 Seat (2)	RPTFE
6 Retainer	A108-CS
7 Gland nut	A108-CS
8 Stem	A108-CS
9 Lever nut (Screw 1/4" to 1/2")	Steel, zinc plated
10 Body	A216-WCB

### DIMENSIONS

PART NO.	SIZE	A	B	C	D	E	WT.
92-101-01	1/4"	0.38	1.14	2.21	1.64	3.87	0.49
92-102-01	3/8"	0.38	1.14	2.21	1.64	3.87	0.49
92-103-01	1/2"	0.38	1.14	2.21	1.64	3.87	0.49
92-104-01	3/4"	0.50	1.34	2.70	1.78	3.87	0.76
92-105-01	1"	0.63	1.51	3.03	2.00	4.78	1.21
92-106-01	1-1/4"	0.81	1.79	3.62	2.18	4.78	1.95
92-107-01	1-1/2"	1.00	1.95	4.00	2.69	5.43	2.92
92-108-01	2"	1.25	2.28	4.73	2.91	5.43	4.73

### VARIATIONS AVAILABLE

- 92-140 Series (316 SS Ball & Stem)

### OPTIONS AVAILABLE

(MORE INFORMATION IN SECTION J)

- Minimum quantities apply
- To specify an option, replace the "01" standard suffix with the suffix of the option.
- To specify multiple options, replace the "01" suffix with the desired suffixes in the numerical order shown below. NOTE: Not all suffixes can be combined together.

(SUFFIX)	OPTION	SIZES
-01	Standard Configuration	All
-P -01-	BSPP (Parallel) Thread Connection	1/4" to 2"
-T -01-	BSPT (Tapered) Thread Connection	1/4" to 2"
-02-	Static Grounded	1/4" to 2"
-04-	2-1/4" Stem Extension (Carbon Steel, Zinc Plated)	1/4" to 2"
-07-	Steel Tee Handle	1/4" to 2"
-08-	90° Reversed Stem	3/4" to 2"
-10-	SS Lever & Nut	1/4" to 2"
-14-	Side Vented Ball (Uni-Directional)	1/4" to 2"
-15-	Wheel Handle, Steel	1/4" to 2"
-16-	Chain Lever - Vertical	1" to 2"
-24-	Graphite Packing, PTFE Body Seal, RPTFE Bearing (Fire Safe API 607, 6th Edition, ISO 10497:2010)	1/4" to 2"
-27-	SS Latch-Lock Lever & Nut	1/4" to 2"
-30-	Cam-Lock Handle & Grounded	1/4" to 2"
-32-	SS Tee Handle & Nut	1/4" to 2"
-39-	SS Hi-Rise, Locking Wheel Handle, SS Nut	1/2" to 1-1/2"
-40-	Cyl-Loc & Grounded	3/4" to 2"
-45-	Less Lever & Nut	1/4" to 2"
-46-	Latch Lock Lever - Lock in Closed Position Only	1/2" to 2"
-47-	SS Oval Latch-Lock Handle & Nut	1/4" to 2"
-48-	SS Oval Handle	1/4" to 2"
-50-	2-1/4" CS Locking Stem Extension	3/4" to 2"
-58-	Chain Lever - Horizontal	1" to 2"
-60-	Grounded Ball & Stem	3/4" to 2"
-65-	Multifill Seats & Graphite Packing	1/4" to 2"
-UA-	AIS (American Iron & Steel) Compliant	All

**Pressure/Temperature Ratings -  
Page M-14, Graph No. 14 (1/4" to 1")  
Page M-13, Graph No. 12 (1-1/4" to 2")**

# FLOW DATA

## FLOW DATA

The listed  $C_v$  "factors" are derived from actual flow testing, at Apollo's Pageland, South Carolina factory. These tests were completed using standard "off the shelf" valves with no special preparation and utilizing standard schedule 40 pipe. It should be understood that these factors are for the valve only and also include the connection configuration. The flow testing is done utilizing water as a fluid media and is a direct statement of the gallons of water flowed per minute with a 1 psig pressure differential across the valve/connection unit. Line pressure is not a factor. Because the  $C_v$  is a factor, the formula can be used to estimate flow of most media for valve sizing.

### FLOW OF LIQUID

$$Q = C_v \sqrt{\frac{\Delta P}{SpGr}}$$

$$\text{or } \Delta P = \frac{(Q)^2 (SpGr)}{(C_v)^2}$$

#### WHERE:

- Q = Flow in US gpm
- $\Delta P$  = Pressure drop (psig)
- SpGr = Specific gravity at flowing temperature
- $C_v$  = Valve constant

### FLOW OF GAS

$$Q = 1360 C_v \sqrt{\frac{(\Delta P) (P_2)}{(SpGr) (T)}}$$

$$\text{or } \Delta P = \frac{5.4 \times 10^{-7} (SpGr) (T) (Q)^2}{(C_v)^2 (P_2)}$$

#### WHERE:

- Q = Flow in SCFH
- $\Delta P$  = Pressure drop (psig)
- SpGr = Specific gravity (based on air = 1.0)
- P2 = Outlet pressure-psia (psig + 14.7)
- T = (temp. °F + 460)
- $C_v$  = Valve constant

**CAUTION: The gas equation shown, is valid at very low pressure drop ratios. The gas equation is NOT valid when the ratio of pressure drop ( $\Delta P$ ) to inlet pressure (P1) exceeds 0.02.**

**NOTE: Only use the gas equation shown if  $(P1-P2)/P1$  is less than 0.02.**

### CV FACTORS FOR APOLLO VALVES (CONTINUED ON M-4)

VALVE	SIZE (IN.)														
	1/4	3/8	1/2	3/4	1	1.25	1.5	2	2.5	3	4	6	8	10	12
70B-140 Series	8.4	7.2	15	30	43	48	84	108	190	370	670	--	--	--	--
70-100/200 Series	8.4	7.2	15	30	43	48	84	108	190	370	670	--	--	--	--
70-300/400 Series	--	--	15	30	43	48	84	108	--	--	--	--	--	--	--
70-600 Series	2.3	4.5	5.4	12	14	21	34	47	--	--	--	--	--	--	--
70-800 Series	8.4	7.2	15	30	43	48	84	--	--	--	--	--	--	--	--
71-AR Series	--	--	--	30	43	48	84	108	190	370	--	--	--	--	--
71-100/200 Series	--	--	--	30	43	48	84	108	190	370	--	--	--	--	--
72-100/900 Series	--	--	26	48	65	125	170	216	--	--	--	--	--	--	--
72-1xx-A/72-9xx-A Series	--	--	26	48	65	125	170	245	--	--	--	--	--	--	--
73A-100 Series	8.4	7.2	15	30	43	48	84	108	--	--	--	--	--	--	--
73-300/400 Series	--	--	26	48	65	125	170	216	--	--	--	--	--	--	--
74-100 Series	8.4	7.2	15	30	43	48	84	108	190	370	670	--	--	--	--
75-100 Series	8.4	7.2	15	30	43	48	84	108	190	370	670	--	--	--	--
76-AR Series	8.4	7.2	15	30	43	48	84	108	190	370	670	--	--	--	--
76F-100 Series	8.1	15	15	51	68	125	177	389	--	--	--	--	--	--	--
76FJ-100 Series	8.1	15	15	51	68	125	177	389	--	--	--	--	--	--	--
76FK-100 Series	8.1	15	15	51	68	125	177	389	--	--	--	--	--	--	--
76-100 Series	8.4	7.2	15	30	43	48	84	108	190	370	--	--	--	--	--
76-300/400 Series	--	--	26	48	65	125	170	216	--	--	--	--	--	--	--
76-600 Series	2.3	4.5	5.4	12	14	21	34	47	--	--	--	--	--	--	--
76J-100 Series	8.4	7.2	15	30	43	48	84	108	190	370	--	--	--	--	--
76J-AR Series	8.4	7.2	15	30	43	48	84	108	190	370	670	--	--	--	--
76K-100 Series	8.4	7.2	15	30	43	48	84	108	190	370	--	--	--	--	--
76K-AR Series	8.4	7.2	15	30	43	48	84	108	190	370	670	--	--	--	--
7K-100 Series	--	--	15	51	68	125	177	389	503	--	--	--	--	--	--
77-AR Series	8.1	15	15	51	68	--	177	389	--	--	--	--	--	--	--

REV. 21APR17

## CV FACTORS FOR APOLLO VALVES (CONTINUED FROM M-3)

VALVE	SIZE (IN.)														
	1/4	3/8	1/2	3/4	1	1.25	1.5	2	2.5	3	4	6	8	10	12
77C-100/200 Series	4.5	7.2	16	36	68	125	177	389	503	--	--	--	--	--	--
77D-140 Series	4.5	7.2	16	36	68	125	177	389	--	--	--	--	--	--	--
77D-640 Series	--	--	--	11	24	35	--	--	--	--	--	--	--	--	--
77G-UL Series	4.5	7.2	16	36	68	125	177	389	503	--	--	--	--	--	--
77W Series	--	--	16	36	68	125	177	389	--	--	--	--	--	--	--
77-100/200 Series	8.1	15	15	51	68	125	177	389	503	--	--	--	--	--	--
79 Series	8.5	8.5	9.8	32	44	66	148	218	440	390	--	--	--	--	--
80 Series	8.4	7.2	15	30	43	48	84	108	190	370	--	--	--	--	--
82-100/200 Series	8.1	14	26	51	68	120	170	376	510	996	1893	--	--	--	--
83A/83B Series	8.1	14	26	51	68	120	170	376	--	--	--	--	--	--	--
83R-100/200 Series	--	--	--	--	--	--	170	376	--	996	1893	--	--	--	--
86A/86B Series	8.1	14	26	51	68	120	170	376	--	--	--	--	--	--	--
86R-100/200 Series	--	--	--	--	--	--	170	376	--	996	1893	--	--	--	--
87A-100 Series	--	--	--	--	--	--	86	104	234	375	673	1099	1902	3890	--
87A-200 Series	--	--	15	19	75	--	195	410	545	1021	2016	4837	9250	15170	22390
87A-700 Series	--	--	--	--	--	--	86	104	234	375	673	1099	1902	3890	--
87A-900 Series	--	--	15	19	75	--	195	410	545	1021	2016	4837	9250	15170	22390
87A-F00 Series	--	--	--	--	75	--	195	410	545	1021	2016	4837	--	--	--
87B-100 Series	--	--	--	--	--	--	--	--	--	375	673	1099	1902	3890	--
87J-100 Series	--	--	--	--	--	--	86	104	234	375	673	1099	1902	3890	--
87J-200 Series	--	--	15	19	75	--	195	410	545	1021	2016	4837	9250	15170	22390
87J-700 Series	--	--	--	--	--	--	86	104	234	375	673	1099	1902	3890	--
87J-900 Series	--	--	15	19	75	--	195	410	545	1021	2016	4837	9250	15170	22390
87K-100 Series	--	--	--	--	--	--	86	104	234	375	673	1099	1902	3890	--
87K-200 Series	--	--	15	19	75	--	195	410	545	1021	2016	4837	9250	15170	22390
87K-700 Series	--	--	--	--	--	--	86	104	234	375	673	1099	1902	3890	--
87K-900 Series	--	--	15	19	75	--	195	410	545	1021	2016	4837	9250	15170	22390
88A-100 Series	--	--	--	--	--	--	86	104	234	375	673	1099	1902	3890	--
88A-200 Series	--	--	15	19	75	--	195	410	545	1021	2016	4837	9250	15170	22390
88A-700 Series	--	--	--	--	--	--	86	104	234	375	673	1099	1902	3890	--
88A-900 Series	--	--	15	19	75	--	195	410	545	1021	2016	4837	9250	15170	22390
88A-F00 Series	--	--	--	--	75	--	195	410	545	1021	2016	4837	--	--	--
88B-100 Series	--	--	--	--	--	--	--	--	--	375	673	1099	1902	3890	--
89-100 Series	8.4	7.2	15	30	43	48	84	108	190	370	--	--	--	--	--
9A-100 Series	8.3	6.7	5.7	10	16	25	40	62	--	--	--	--	--	--	--
90-100 Series	8.3	6.7	5.7	10	16	25	40	62	--	--	--	--	--	--	--
92-100 Series	8.3	6.7	5.7	10	16	25	40	62	--	--	--	--	--	--	--
93-100 Series	8.3	6.7	5.7	10	16	25	40	62	--	--	--	--	--	--	--
94A-100/200 Series	6	7	19	34	50	104	268	309	629	1018	1622	--	--	--	--
96-100 Series	8.3	6.7	5.7	10	16	25	40	62	--	--	--	--	--	--	--
399-100 Series	8.4	7.2	15	30	43	48	84	108	190	370	--	--	--	--	--
489-100 Series	8.4	7.2	15	30	43	48	84	108	190	370	--	--	--	--	--

**1500 CWP**

**(CS) ASTM A216-WCB OR ASTM A105**

**GRAPH 11**

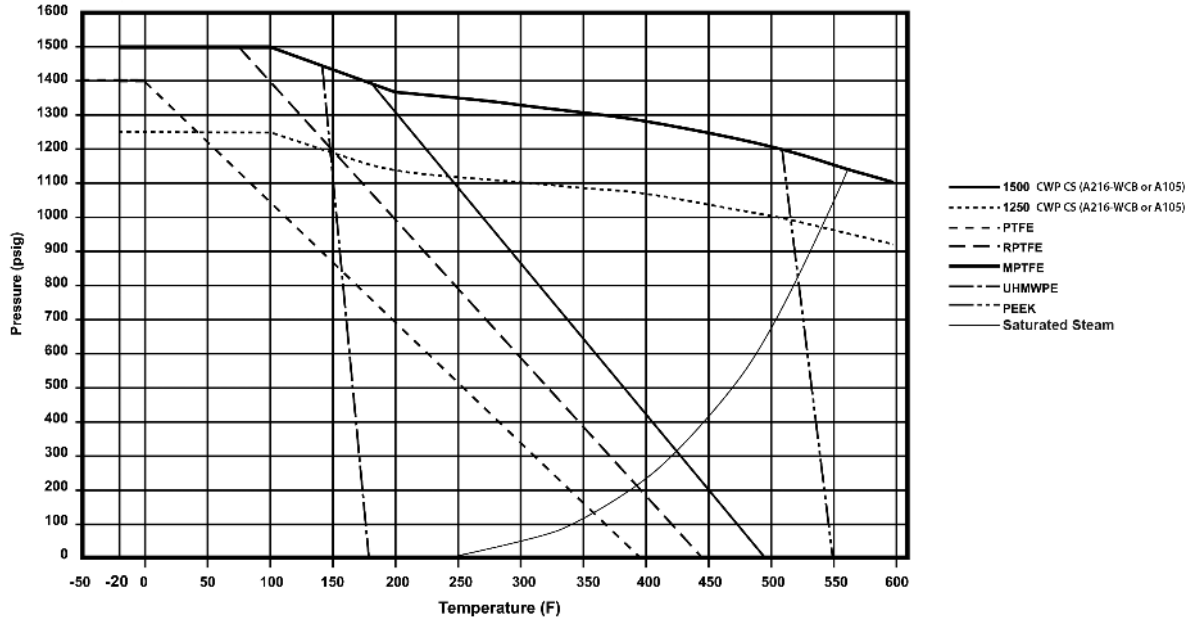

**1500 CWP**

**(SS) ASTM A351-CF8M**

**GRAPH 12**

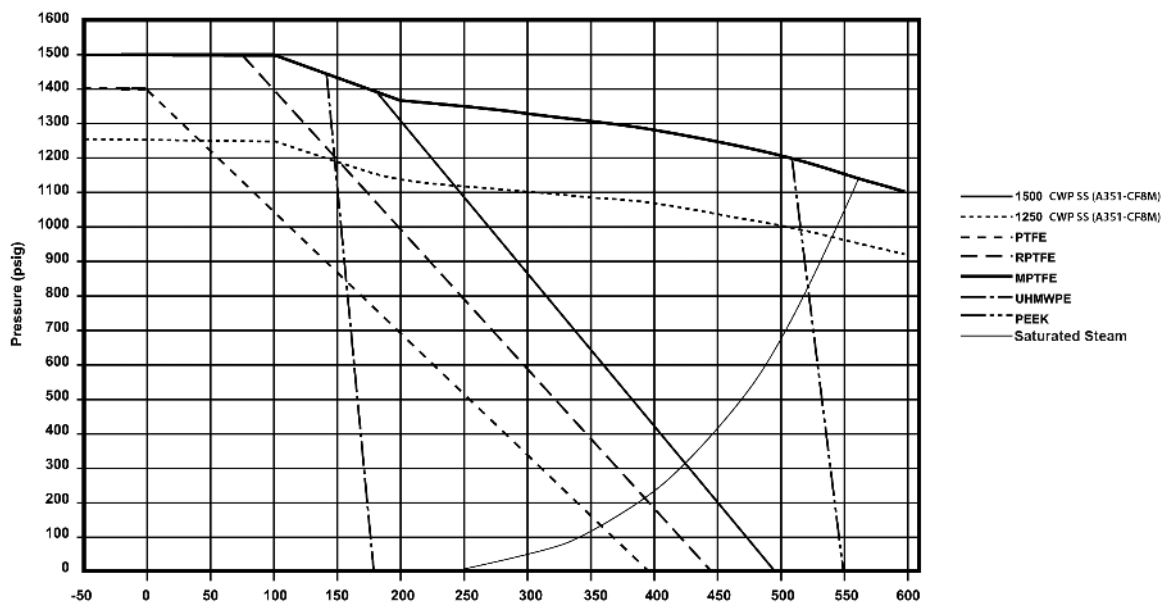

**2000 CWP**

**(CS) ASTM A216-WCB OR ASTM A105**

**GRAPH 13**

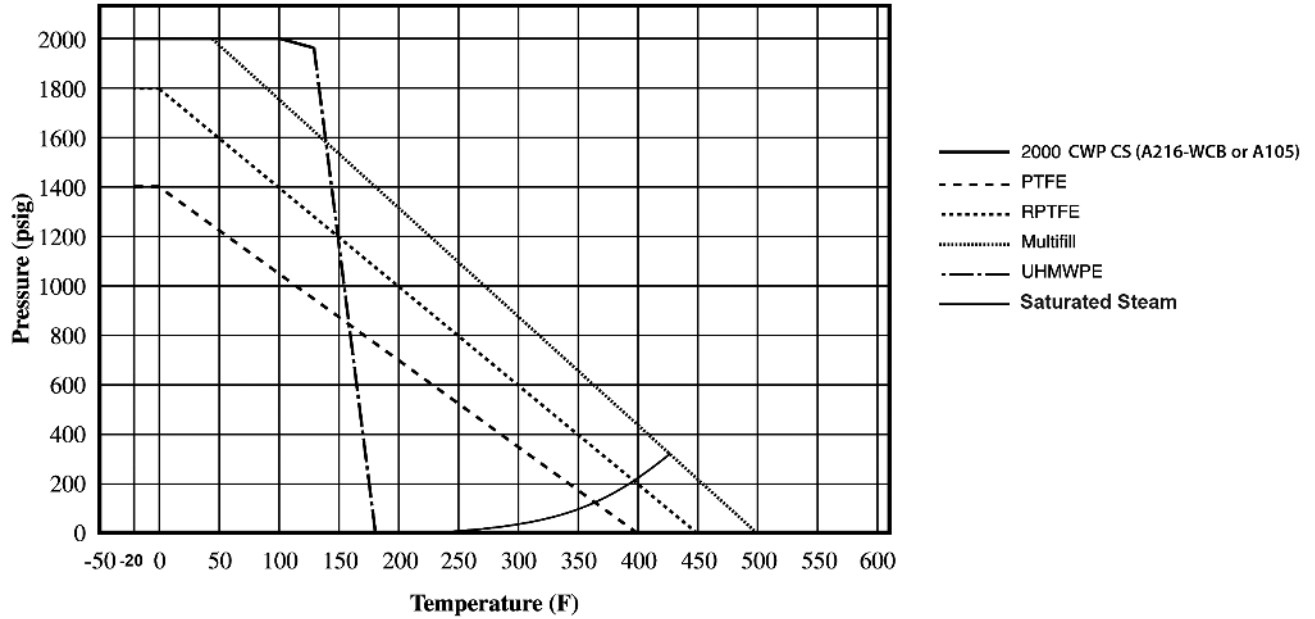

**2000 CWP**

**(SS) ASTM A351-CF8M**

**GRAPH 14**

