

- 11) With the ball in the closed position, thread the retainer into the body and torque to manufacturing specification to secure the body joint. *Contact factory for torque values.*
- 12) Cycle the valve to the open position and verify proper operation and alignment of handle and/or mechanism.

**Note: Always test valve and system before putting the system into service.**

**PARTS ILLUSTRATION**

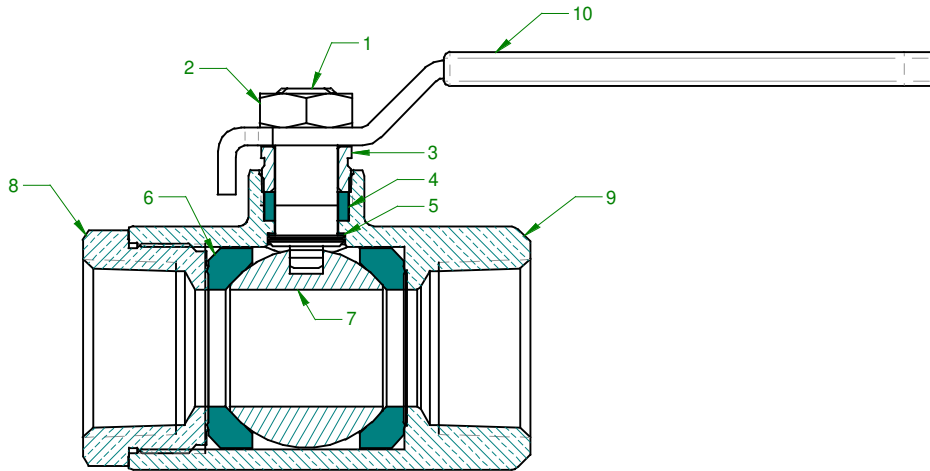

NO	DESCRIPTION
1	STEM
2	STEM NUT
3	PACKING GLAND SCREW
4	PACKING
5	STEM BEARING
6	SEAT
7	BALL
8	RETAINER
9	BODY
10	HANDLE



**3 – WAY DIVERSION BALL VALVES  
70600, 70900 and 76600 SERIES  
INSTALLATION, OPERATION & MAINTENANCE GUIDE**

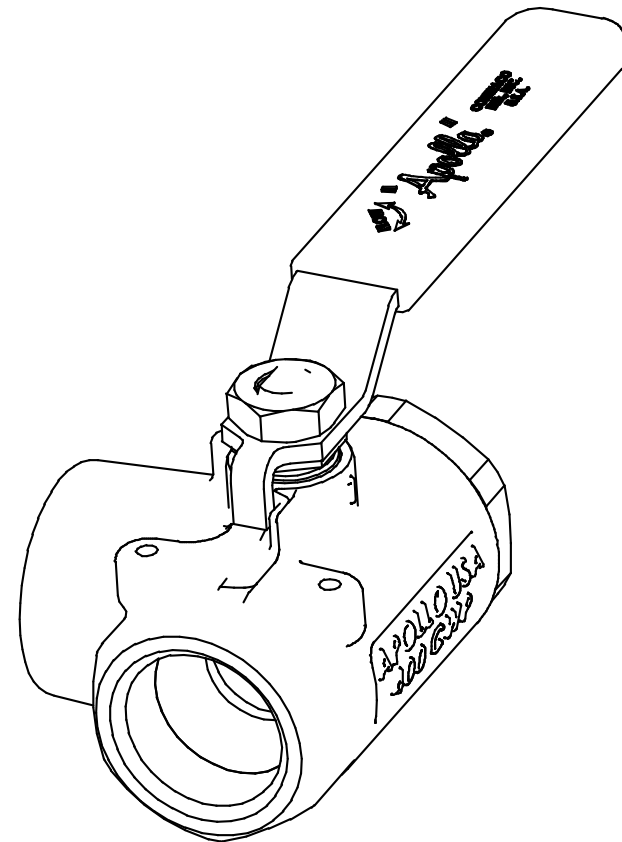

Two piece threaded and solder end Apollo Ball valves are bi-directional. They may be installed in vertical or horizontal pipe runs without regard to flow direction and without regard to stem orientation.

Note: Valves must be installed in piping systems that comply with the applicable portions of the ASME B31 standards. Special considerations must be taken with respect to pipe line expansions and contractions and the media expansion and contractions within the piping system.

### **Threaded End Valves**

Mating pipe connections should be accurately threaded, clean and free of foreign material or metal shavings. Two to four wraps of PTFE pipe tape (or pipe dope, but not both) should be applied to the male threads. Two wrenches must be used when mating up pipe joints to these valves. Apply one flat-faced wrench on the valve hex closest to the pipe joint being tightened and use a pipe wrench on the pipe to prevent transmitting torque through the valve body joint. Typical wrench make-up is 1-1/2 turns after installing the pipe hand-tight. Do not overtighten the valve onto the pipe, as this can damage or distort the valve. Do not reverse-rotate after tightening as this can damage the body/retainer seal.

### **Solder End (Sweat In) Valves**

Caution: Use only solders with melt points below 500°F.

Caution: Valves should only be soldered in the fully open or closed position.

During soldering, the mid-portion of the valve body should not exceed 300°F. This can be monitored using Tempilstik® or an infra-red temperature sensor. Depending on the fuel selected and the orientation of the installation it may be necessary to wrap the valve body with wet rags or employ other heat absorbing techniques. Select a torch tip size appropriate for the tube size being soldered. The flame must be directed away from the valve body, concentrated on the solder cup. The cup should be heated evenly. Allow heated joints to cool naturally. Quenching with water will cause unnecessary stress on the joint.

Fuel	Flame temp w/Oxygen
Propane	3596°F (1980°C)
Natural Gas	3560°F (1960°C)
MAPP Gas	3670°F (2021°C)
Acetylene	4622°F (2550°C)

Warning: Excessive heat input will damage the body seal resulting in leaks at the valve body joint. In extreme cases, seats and stem packing may also be damaged.

### **OPERATION**

The valve handle is marked showing proper "FLOW" direction in respect to lever position at extreme end of lever travel.

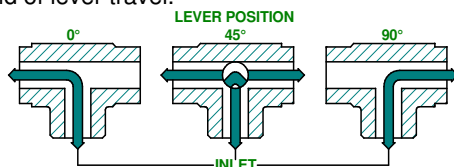

In accordance with the U.S. Safe Drinking Water Act (SDWA), it is illegal to use this product in the United States for potable water services (water intended for human consumption).

### **Regular Maintenance**

Normal stem packing wear can be compensated for by tightening the packing gland screw. (Wrench part number H371400 is available to ease this operation.) Tighten the packing gland screw clockwise in 1/8 turn increments until observed leakage stops. If all of the adjustments to the packing gland screw have been made, remove the handle nut, handle and packing gland screw and add one or two replacements bearings on top of the old packing. Reinstall the handle and handle nut.

Caution: Do not disassemble valve while under pressure nor with entrapped hazardous fluids therein.

### **Valve Repair**

#### **Disassembly**

- 1) Operate the valve 0° to 90° to assure there are no trapped fluids or pressure in the body cavity. Place the handle in the position such that is parallel to the inlet port.
- 2) Remove the handle nut, handle and packing nut. Set aside for reuse.
- 3) Install pipe plugs in the body and retainer ports of NPT valves to prevent collapsing those areas.
- 4) Remove the retainer from the body. It may be necessary to heat the body joint above 450°F to breakdown the sealant used to secure the valve halves.
- 5) Remove the ball from the body cavity. Inspect the ball. If it is scarred, it is recommended that the whole valve be replaced, but replacement balls are available. Clean and set aside good balls for reuse.
- 6) Push the stem from the outside into the body cavity. Inspect the stem. If it is scarred or has damaged threads, replacements are available. Clean and set aside good stems for reuse.
- 7) Remove all seals and seats from the body and retainer then discard. Inspect the body and retainer for damage. If damaged, scrap the valve as replacements of these components are not offered.

**Note: Union end valves cannot be easily repaired; therefore it is recommended that the main valve section be replaced.**

#### **Re-Assembly**

- 1) Install stem bearing on to stem.
- 2) Fit stem into body from the retainer end and position the stem with the handle flats perpendicular to the flow axis.
- 3) Install stem packing over stem and fit into body recess.
- 4) Install packing gland screw into the threaded stem area.
- 5) Tighten the gland screw to manufacturing torque specifications: *Contact factory for torque values.*
- 6) Install the handle and handle retaining hardware.
- 7) Apply suitable light lubricant to seat and fit into the seat pocket of the body.
- 8) Install the ball. Make sure that the handle is parallel to the inlet port.
- 9) Apply suitable light lubricant to seat and fit into the seat pocket of the retainer.
- 10) Apply an adequate amount of thread locking compound (Loctite 609, 648 or 680) to the retainer threads. Enough to cover no less than two complete threads shall be applied to the leading threads opposite the retainer shoulder.

**Note: Valves in oxygen service can only be sealed with oxygen compatible thread sealant.**

## Amendment Register

<b>Date</b>	<b>ECN</b>	<b>Revision</b>	<b>Page</b>	<b>Description</b>	<b>Initiator</b>	<b>Reviewed</b>
07/16/18	M16975	C	1-2	Updated NPT thread instructions & SDWA warning	DRP	WGH