

DCDA4S

double check detector assembly



USC-FCCCHR



Job Name:	
Job Location:	
Engineer:	
Contractor:	
Tag:	
PO#:	
Rep:	
Wholesale Dist.:	

DESCRIPTION

The Apollo® Model DCDA4S Double Check Detector Assembly (Formerly Model DCDA) is designed to prevent contamination of the potable water supply due to back-siphonage or backpressure from substances that are non-health hazards. The device consists of a mainline double check valve with a bypass line. The by-pass consists of a water meter and an approved Apollo® double-check valve with Apollo® ball valves as shut-offs. The by-pass serves to measure water use of up to 3 gpm.

FEATURES

- Lightweight
- Short Lay Length
- Low Pressure Loss
- Modular Check Valves
- Individual Access to Check Valves
- Corrosion Resistant Epoxy-Coated Ductile Iron Body
- US Patents #5,711,341 and #6,343,618
- **Assembled and Tested in the USA**

PERFORMANCE RATING

- Maximum Working Pressure: 175 psi
- Temperature Range: 33°F - 140°F
- Hydrostatic Test Pressure: 350 psi

APPROVALS

- Horizontal and Vertical Up Approvals
- ASSE 1048
- CSA B64.5
- FM Approved
- UL® Classified
- C-UL® Classified
- Approved by the Foundation for Cross-Connection Control and Hydraulic Research at the University of Southern California
- Approved by the City of New York

*UL and FM installations must include indicating-type shutoff valves.

STANDARD MATERIALS LIST

BODY (MAINLINE)	Epoxy-coated (FDA) Ductile Iron
BYPASS DC	Bronze
COVERS (10")	Epoxy-coated (FDA) Ductile Iron
CHECK VALVES (10")	Bronze
SPRINGS	Stainless Steel
SEAT DISCS	Chloramine-Resistant EPDM

PART NUMBER MATRIX

4S	60 X	X	X
	SIZE	METER OPTION	SHUT-OFF VALVES
4S - STANDARD	G - 10"	C - CUBIC FEET/MIN	2 - NRS FLANGED X NRS FLANGED
		E - GALLONS/MIN	3 - OS&Y FLANGED X OS&Y FLANGED
		G - LESS METER	5 - EPOXY-COATED FLANGED BALL VALVES
			6 - OS&Y FLANGE X POST INDICATOR FLANGE
			7 - OS&Y FLANGE X OS&Y GROOVE
			8 - OS&Y GROOVE X OS&Y GROOVE
			10 - OS&Y FLANGE X POST INDICATOR GROOVE

DIMENSIONS

SIZE	10"
A	55-3/4
B	29-1/2
C (OS&Y OPEN)	46
D	8
E	10-3/4
H	11-1/2
Test Cocks (Mainline)	3/4 NPT
Test Cocks (Bypass)	1/4 NPT
WEIGHTS	LB.
Net Wt. (Less Gate Valves)	490
Net Wt. (w/ OS&Y Valves)	1340
Net Wt. (w/ Elbows & OS&Y Valves)	1714
Net Wt. (w/ Post Indicator)	1277

Nominal dimensions are shown. Allowances must be made for manufacturers' tolerances.

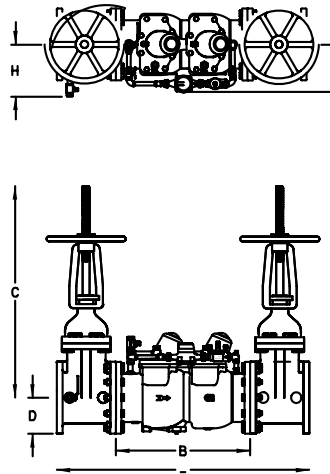

FLOW CURVES

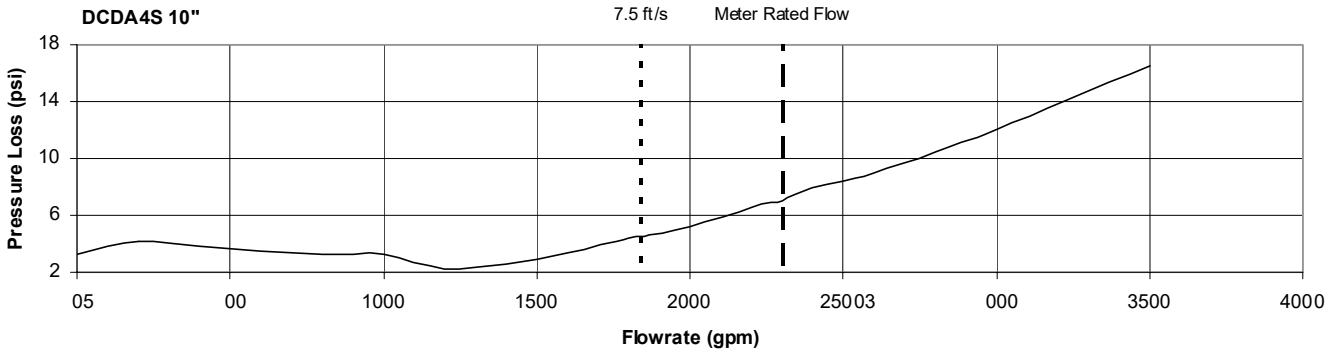

Flow curves directly reflect data collected by an independent laboratory. Flow curves shown were recorded with gate shut-off valves. Contact factory for more information. All data points are based on ASSE increasing flow data, from zero GPM to rated flow (opening curve). For high flow rates/pressure loss information – contact factory.